

ANTHONY
LIFTGATES, INC.®

DCT



INSTALLATION, OPERATION, AND MAINTENANCE MANUAL

MODEL	CAPACITY	BED HEIGHT
DCT-25	2500 lbs	42 - 57"
DCT-25-WR	2500 lbs	42 - 57"
DCT-33	3300 lbs	46 - 57"
DCT-33-WR	3300 lbs	46 - 57"

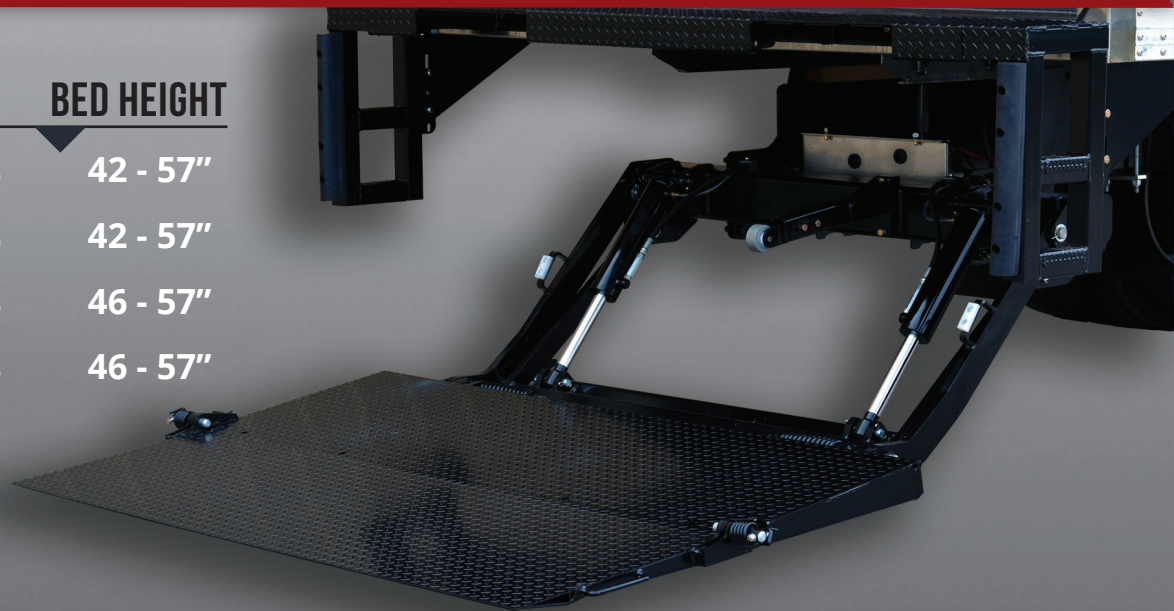

Read, understand, and follow the manual. This manual provides information and procedures to safely install, operate, and maintain the liftgate.



For Serial Number 116751 and Greater

QUALITY, RELIABILITY, CUSTOMER SERVICE

MADE IN THE USA 

Contents

1. General Information Section	4	4.4 Cut-Off Solenoid Connection	27
1.1 Introduction	4	4.5 Cut-Off Switch Connection.	27
1.2 General Safety.	4	4.6 Bolt-On Floor Extension.	28
1.3 State and Federal Regulations	4	5. Lifting Device	30
1.3.1 Brakes	4	6. Trailer Sub Frame Installation	31
1.3.2 Lighting	4	7. Decals	32
1.3.3 Rear Impact Guards	4	7.1 Decal Locations	32
1.4 Basic Installation Instructions.	4	7.2 Replacement Parts and Hazard Decals.	32
1.5 Registration	5	7.2.1 Customer Installed Decals	32
1.6 If Installation Help Is Required.	5	7.2.2 Factory Installed Decals	32
1.6.1 Installation and Maintenance (Dealer).	5	7.3 Decal Illustrations.	33
1.6.2 Customer Service and Parts (End User)	5	8. Operation Section	35
1.7 Warranty	5	8.1 General Operating Safety Instructions.	35
1.8 Replacement Parts and Hazard Decals.	5	8.2 Operating Instructions	36
2. Safety.	6	9. Maintenance Section	38
2.1 Safety Is Your Responsibility	6	9.1 Monthly Inspection	38
2.2 Safety Signal Words	6	9.2 Semi-Annual Inspection.	38
2.3 Safety Icons Nomenclature	6	9.3 Maintenance and Troubleshooting Procedures.	39
2.3.1 Personal Protection/Important Information	6	9.3.1 Platform Adjustment (adding shims)	39
2.3.2 Prohibited Actions	6	9.3.2 Replacing the Fuse	39
2.3.3 Hazard Avoidance	6	9.3.3 Checking Motor Start Solenoid and Power Cut-off Solenoid	40
2.4 Safety Rules.	7	9.3.4 Checking the Power Cable	40
2.4.1 Operator / Bystander Safety	7	9.3.5 Checking Lowering Valve Cartridge and Solenoid	40
2.4.2 Personal Protection.	7	9.3.6 Solenoid Valve Screen	41
2.4.3 Equipment / Tools / Parts	7	9.3.7 Replacing Solenoid Valve	41
2.4.4 Battery / Fuel Tank Safety.	8	9.3.8 Checking System Pressure.	41
2.4.5 Cutting Torch / Welding Safety	8	9.3.9 Checking Cylinder Piston Seals (drifting - caused by seal leakage).	42
2.5 Welding or Grinding Galvanized or Stainless Steel Material	8	9.3.10 Checking Flow Control Valve	42
2.5.1 Galvanized Metal.	8	9.3.11 Checking Control Switch Fuse	42
2.5.2 Stainless Steel.	8	10. Troubleshooting	43
3. Nomenclature.	9	10.1 Troubleshooting Guide.	43
3.1 Platform Nomenclature	9	11. Inspection Record	46
3.2 Gravity-Down Power Unit Nomenclature	9	12. Limited Warranty	47
3.3 Power-Down Power Unit Nomenclature	10	12.1 Limited Warranty	47
4. Installation Section.	11	12.2 Warranty Policy and Procedure	47
4.1 Installers Safety.	11		
4.2 Tools Required.	11		
4.3 Bed Height and Clearance Requirements	12		
4.3.1 Preparation	12		
4.3.2 Installing Floor Extension	14		
4.3.3 Adjust Width of Mounting Plates	16		
4.3.4 Positioning the Liftgate	17		
4.3.5 Attaching Liftgate to Truck Frame	18		
4.3.6 Installing Optional DOT Tubular Bumper	21		
4.3.7 Mounting Control Switch and Routing the Power Cable	22		
4.3.8 Adjust the Wheel Arm	24		
4.3.9 Adjust Latch Pin	25		
4.3.10 Installing DOT Lighting, Decals, and Any Components Not Part of Liftgate	25		
4.3.11 Final Inspection Checklist	26		

1. General Information Section

1.1 Introduction

Congratulations on selecting an Anthony Liftgates TuckUnder™ liftgate.

All Anthony tuckunder model liftgates are factory assembled, energized, and tested to ensure the highest quality performance standards. DCT liftgates ship completely assembled for fast, clean, and easy installation.

To ensure your liftgate will perform to your expectations, we have provided this Installation Manual, which is designed to provide you with the necessary installation instructions and safety precautions for the installation of the TuckUnder™ liftgate.



Typical Anthony Liftgates Dual Cylinder Tuckunder Liftgate.

1.2 General Safety



Read, Understand, and Follow the Manual

The success or failure of this liftgate to properly and efficiently operate will depend on a thorough and proper installation. Failure to read, understand, and follow the installation instructions and safety recommendations in this manual, before installing the liftgate, can result in serious injury or death to the operator or bystander.

Also, read and understand the operating instructions in the Operation section before beginning the installation.

Proper installation and operation is your responsibility.

1.3 State and Federal Regulations

1.3.1 Brakes



When installed, the operation or weight of this liftgate must not alter or prevent vehicle compliance to any existing State or Federal standards, such as FMVSS 105 – Hydraulic And Electric Brake Systems. Each truck frame manufacturer's recommendations should be consulted for compliance.

Also, make sure the weight of the liftgate and its fully loaded capacity will not overbalance the truck, possibly raising the front wheels off the ground.

1.3.2 Lighting



When installed, the transport position of this liftgate must not alter or prevent vehicle compliance to any existing State or Federal standards such as FMVSS 108 – Lamps, Reflective Devices, and Associated Equipment. Each truck manufacturer's recommendations should be consulted for compliance.

1.3.3 Rear Impact Guards



When installed, the transport position of this liftgate must provide protection against rear impact, using State or Federal standards, such as FMVSS 223 – Rear Impact Guards and FMVSS 224 – Rear Impact Protection.

It is the duty of the installer to make sure that guards are installed, if necessary, to fulfill these standards. Anthony Liftgates offers a bolt-on bumper, which will meet the requirements of this standard. Each truck manufacturer's recommendations should also be consulted for compliance.

1.4 Basic Installation Instructions

1. This liftgate should only be installed by someone with sufficient skills to understand the installation and operation procedures, along with the use of any equipment or tools used to install the liftgate. This manual provides typical installation instructions, which we believe to be the most desirable sequence. These instructions cannot replace a qualified installer with clear thinking and basic knowledge.
2. This manual provides easy-to-follow instructions, along with photos and illustrations, which will help guide the installation process. Safety precautions have been clearly identified throughout each section of this manual and must be followed.
3. A complete explanation of the safety terminology and recommendations are included in section "2. Safety" on page 6 of this manual and should be read thoroughly before proceeding.
4. We urge the installer to call our qualified personnel if you have installation questions.

- Most problems occur when positioning the adapter frame tube and mounting plates. Before completely welding the mounting plates to the truck frame, call us if you find the liftgate is not operating properly.

1.5 Registration

Record the serial number, model number, date of installation, and load capacity for easy reference when contacting Anthony Liftgates with questions. You can register online by going to www.anthonyliftgates.com and selecting the CUSTOMER SERVICE tab and then Product Registration.

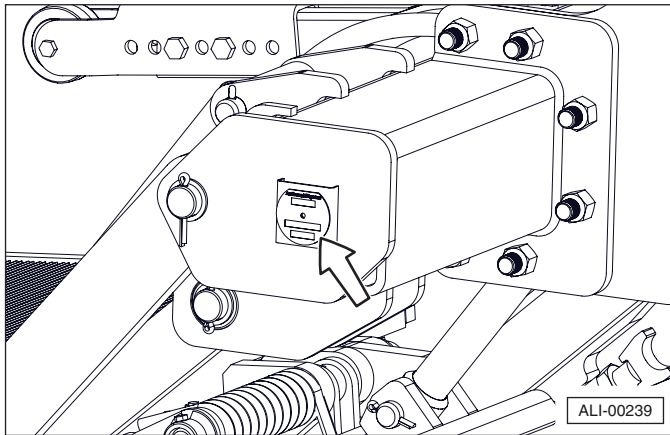

Serial Number Identification Plate.

Registration and Warranty Information	
Serial No.	
Model No.	
Date of Installation	
Lift Capacity	

1.6 If Installation Help Is Required

1.6.1 Installation and Maintenance (Dealer)

For additional information, refer to the DCT TuckUnder™ liftgate website www.anthonyliftgates.com. To find the most current version of the reference material, choose LIFTGATES, TUCKUNDER™, DCT, and then DOWNLOADS.

If you have any doubts or questions about installation, call us. Before doing so, have the serial number, model number, and lift capacity of your liftgate available.

Anthony Liftgates, Inc.
1037 West Howard Street
Pontiac, Illinois 61764
(815) 842-3383 or 800-482-0003

1.6.2 Customer Service and Parts (End User)

For service or ordering replacement parts, contact an authorized dealer by going to www.anthonyliftgates.com and selecting the FIND A DEALER tab. Enter your zip code to find the nearest authorized service location.

1.7 Warranty

Refer to “12. Limited Warranty” on page 47 for the complete warranty statement.

NOTICE

The liftgate must be installed according to these instructions or the warranty will be void.

- Unauthorized modifications may cause improper operation or other unforeseen problems or dangers. If any deviation is deemed necessary, written permission must be obtained from Anthony Liftgates.
- All decals must be attached by the installer and legible, or all warranties are void.

1.8 Replacement Parts and Hazard Decals

Dealers: To order replacement parts or hazard/informational decals, contact us through your normal dealer channels.

End Users: For ordering replacement decals, contact an authorized dealer by going to www.anthonyliftgates.com and selecting the FIND A DEALER tab. Enter your zip code to find the nearest authorized service location.

SAFETY INSTRUCTIONS



To prevent the personal injury of the end user from not being aware of safety recommendations, the installer must make sure all decals are attached to the liftgate and truck, and are legible.

2. Safety

2.1 Safety Is Your Responsibility

It is the responsibility of the installer to understand proper installation and operating procedures. Be aware of the inherent dangers in the use of this product and the tools used to install it. Read and understand all Warnings, Cautions, Notices, Safety Instructions, and Notes in this manual, on the liftgate, or on the truck.

Accidents can often be avoided by being alert and recognizing potentially hazardous situations. The safety information in this manual serves as a basic guide in an attempt to prevent injury or death.

Anthony Liftgates cannot anticipate every possible circumstance that might involve a potential hazard. The warnings in this manual and on the product itself are, therefore, not all-inclusive. If tools, procedures, work methods, or operating techniques are used that are not specifically mentioned by Anthony Liftgates, you must satisfy yourself that they are safe for you and for others.

DO NOT proceed with any installation procedure if doubt arises about the correct or safe method of performing any procedure found in this manual. If you have any doubts or questions about installation, call us.

2.2 Safety Signal Words

 Personal injury hazards are identified by the "Safety Alert Symbol" and followed by a signal word such as WARNING or CAUTION to indicate the severity of the hazard.

 This safety alert icon surrounds an image showing a specific type of injury which should be avoided. These icons are shown in "2.3.3 Hazard Avoidance" on page 6.

 **Indicates a potentially hazardous situation which, if not avoided, COULD result in death or serious injury.**

 **Indicates a potentially hazardous situation which, if not avoided, MAY result in minor or moderate injury.**

 **Indicates that equipment or property damage can result if instructions are not followed.**





 **Indicates specific safety-related instructions or procedures.**

Note: Contains additional information important to a procedure.

2.3 Safety Icons Nomenclature



















This manual and the equipment have numerous safety icons which provide important operating instructions, which alert you to potential personal injury hazards.

2.3.1 Personal Protection/Important Information

-  Read the manual
-  Eye protection
-  Face shield / welding helmet
-  Breathing protection
-  Head protection
-  Protective shoes
-  Hand protection
-  Use two people when lifting heavy objects
-  Use proper tools
-  Set parking brake
-  Remove key
-  OEM parts
-  Properly installed parts
-  Damaged safety sign
-  Egress / Ingress (three point contact)
-  Do not alter or modify
-  Do not weld
-  No smoking
-  No open flame

-  No alcohol
-  No drugs
-  No forklift

2.3.3 Hazard Avoidance

-  Safety alert symbol
-  Slipping injury
-  Tripping injury
-  Pinch point hazard
-  Pinch hazard (foot)
-  Dangerous fumes
-  Adequate ventilation
-  Crush hazard
-  Crush hazard
-  Crush hazard (chock wheels)
-  Chock wheels / rollover hazard
-  Fall hazard (truck)
-  Fall hazard (platform)
-  Damaged parts hazard
-  Do not exceed weight capacity
-  Fire hazard
-  Sparks / fire hazard
-  Battery gas hazard

2.3.2 Prohibited Actions

2.4 Safety Rules

2.4.1 Operator / Bystander Safety

WARNING  Unsecured loads, when moved on the liftgate, can shift or fall. To prevent personal injury or death, make sure loads are securely fastened to the liftgate or restrained by cart stops, retention ramp, or fencing.

All users of this liftgate must be at least 18 years old and have read and understood all operation instructions and safety decals before use.

Installers: Many liftgates are designed with a platform restraining system such as a cart stop, retention ramp, fencing, straps, etc. to keep certain types of cargo from rolling off of the platform. Installers must make sure these devices are operating properly once the liftgate is installed.

Operators: Restraining devices should be used whenever unstable loads are placed on the platform. These devices prevent the possibility of severe personal injury or death due to cargo shifting and/or falling from the liftgate platform.



2.4.2 Personal Protection



WARNING  Do not work under the liftgate while it is suspended from the lifting device. Failure of the lifting device could cause serious crushing injuries. Do not remove the lifting device until the liftgate is securely tack welded onto the truck frame.



CAUTION    

When installing or operating this unit, wear appropriate personal protective equipment. This list may include, but is not limited to:



- A hard hat.
- Protective shoes with slip resistant soles.
- Protective goggles, glasses, or face shield.
- Protective clothing.

  Anthony Liftgates recommends not riding the liftgate; however, if the operation requires it, make sure your footing is stable before raising or lowering the platform. Always stand away from the edge. When on the ground, always stand clear of the liftgate when it is operating.

  Do not attempt to install the liftgate under the influence of drugs or alcohol. Consult your doctor before using the liftgate while taking prescription medications.

  To prevent personal injury, clean up any spilled fluids immediately. To avoid tripping, do not leave tools or components laying around in the work area.

  Failure to prevent the truck from moving during the installation of the liftgate could result in a serious crushing injury.

  Always use/set the truck's parking brake and remove the ignition key before installing the liftgate. Failure to follow this recommendation can result in injury.

 Do not place hands or feet in pinch points.

 Do not place your feet under the liftgate or between the platform and floor extension.

 To prevent injury, the liftgate and its related components should only be installed by a qualified installer having knowledge and skill in using a lifting device, a cutting torch, and welding equipment.

 To prevent possible injuries due to improper operation, make sure all decals are attached to the liftgate and/or truck and are legible at all times.

2.4.3 Equipment / Tools / Parts

CAUTION  Do not install this unit if it is damaged. If you believe the unit has a defect, which could cause it to work improperly, you should immediately stop the installation and remedy the problem before continuing.

 Make sure the liftgate or truck will not be damaged or made unsafe by the installation or use of the liftgate.

 Never secure the power cable to anything which allows it to contact sharp edges, other wiring, fuel tank, fuel lines, brake lines, air lines, exhaust system, or any other object that could cause the power cable to wear or be damaged. A cut battery cable can cause sparks and/or component damage resulting in loss of vehicle control, serious injury, or even death.

 If replacement parts are necessary, genuine factory OEM replacement parts must be used to restore the liftgate to the original specifications. Anthony Liftgates will not accept responsibility for damages as a result of using unapproved parts. If non-OEM replacement parts are used, the warranty will be voided.

SAFETY INSTRUCTIONS   Do not modify safety devices. Do not weld on the liftgate assembly, except the adapter frame tube. Unauthorized modifications may impair its function and safety.

 Make sure all parts are in good working condition and properly installed. Replace any damaged parts immediately.



2.4.4 Battery / Fuel Tank Safety

 **WARNING**    To prevent serious bodily injury, keep sparks, lighted matches, and open flames away from the top of the battery, because battery gas can explode. Always follow all the manufacturers' safety recommendations when working around the truck's battery.

 Take precautions to avoid sparks coming into contact with the truck's fuel tank, brake lines, or other flammable components. Sparks can cause an explosion of combustible materials, resulting in serious injury or death.

2.4.5 Cutting Torch / Welding Safety

 **WARNING**  Take precautions to avoid sparks from contacting the truck's fuel tank, brake lines, or other flammable components. Sparks can ignite combustible materials, resulting in serious injury or death.

   Always weld or use a cutting torch in a well-ventilated area and, if in an enclosed area, vent the fumes to the outside. Breathing welding smoke and paint fumes can cause serious injury.

 Always follow all State and Federal health and safety laws and/or local regulations when using an arc welder, mig welder, or cutting torch. Also, follow all manufacturers' safety guidelines. If other people are present during the installation of the liftgate, make sure the assembly area is shielded from their view.

 To avoid eye injury during welding, always wear a welding helmet with the proper lens to protect your eyes.

 To avoid eye injury while using a cutting torch, always use eye protection with the proper lens to protect your eyes.

2.5 Welding or Grinding Galvanized or Stainless Steel Material

2.5.1 Galvanized Metal

 **CAUTION**   

Follow all OSHA and other workplace safety standards when welding galvanized steel, which creates zinc oxide fumes. Always grind the coating off in the area to be welded and provide adequate ventilation to avoid breathing the fumes.

Always wear the proper breathing protection when grinding or welding. Use ventilation or vacuum systems to remove any contaminated air from the work area.

Metal Fume Fever:

When zinc vapor mixes with the oxygen in the air, it reacts instantly to become zinc oxide, which is non-toxic and non-carcinogenic.

Zinc oxide that is inhaled is absorbed and eliminated by the body without complications or chronic effects.

Exposure to zinc oxide fumes causes a flu-like illness called metal fume fever.

Symptoms include headache, fever, chills, muscle aches, nausea, vomiting, weakness, and tiredness.

There are no long-term health effects. Metal fume fever typically begins about four hours after exposure, and full recovery occurs within 48 hours.

2.5.2 Stainless Steel

Follow all OSHA and other workplace safety standards when welding stainless steel, which creates hexavalent chromium fumes that can irritate the nose, throat, and lungs.

Repeated or prolonged exposure can damage the mucous membranes of the nasal passages and result in ulcers. In severe cases, exposure causes perforation of the septum (the wall separating the nasal passages).

Always wear the proper breathing protection when grinding or welding. Use ventilation or vacuum systems to remove any contaminated air from the work area.

3. Nomenclature

3.1 Platform Nomenclature

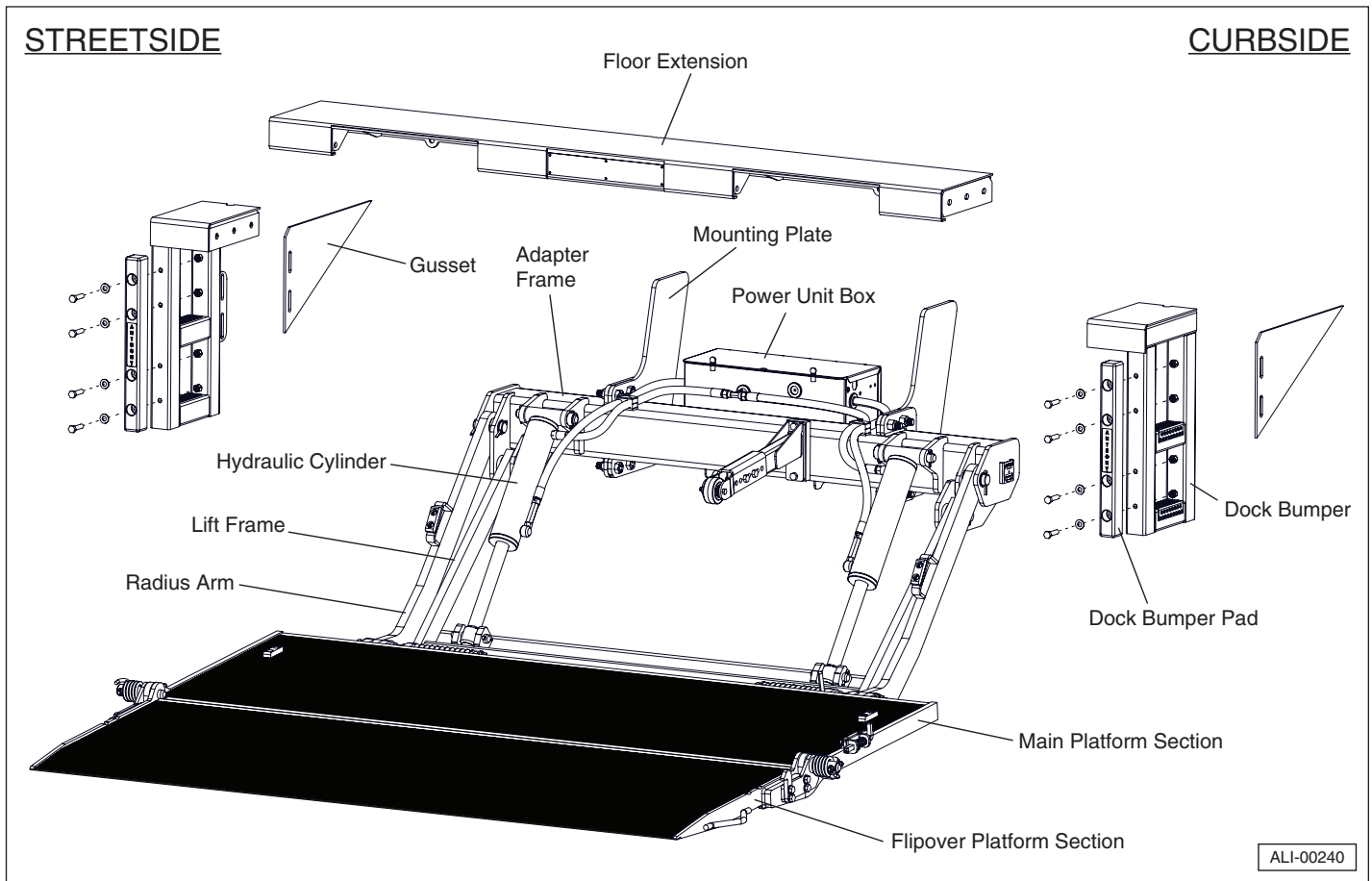

3.2 Gravity-Down Power Unit Nomenclature

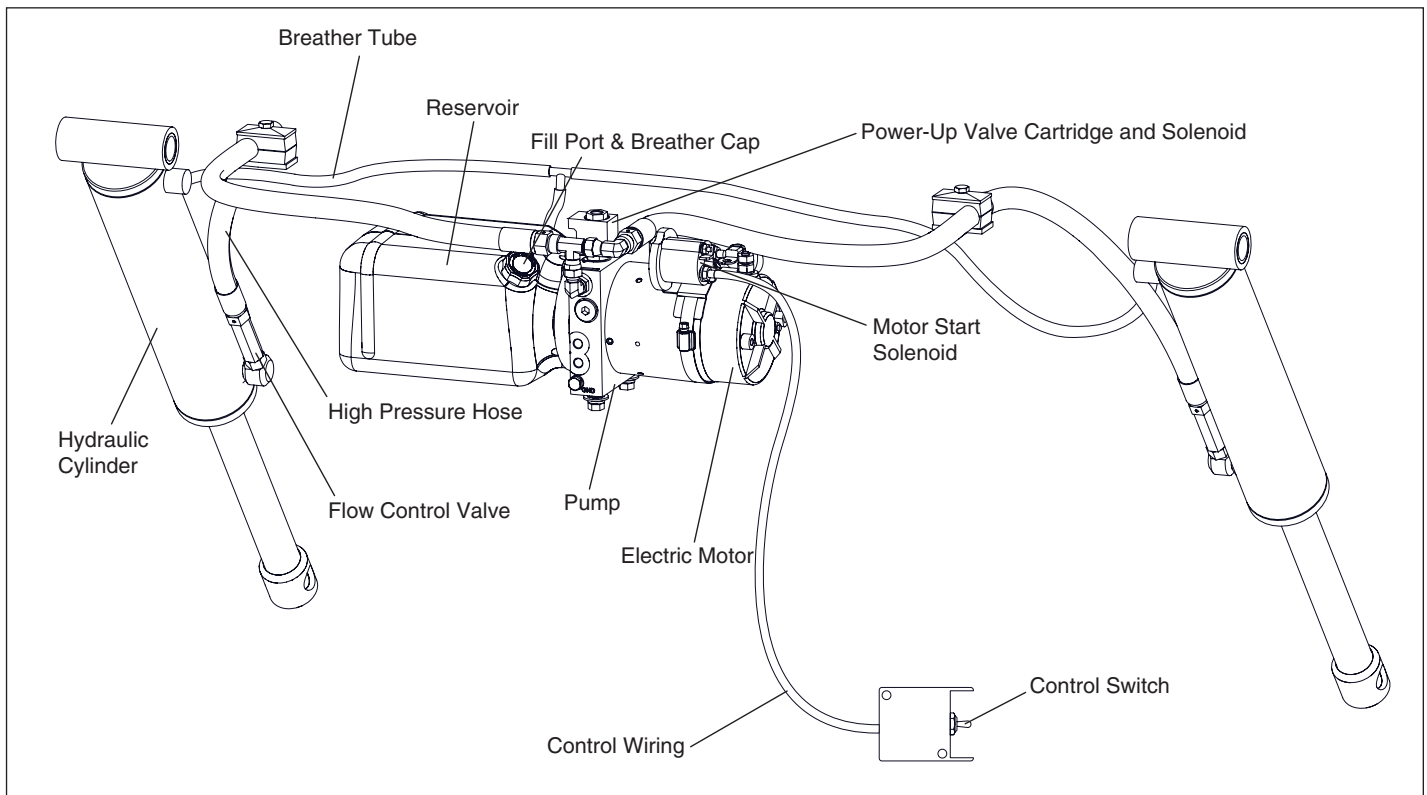

3.3 Power-Down Power Unit Nomenclature

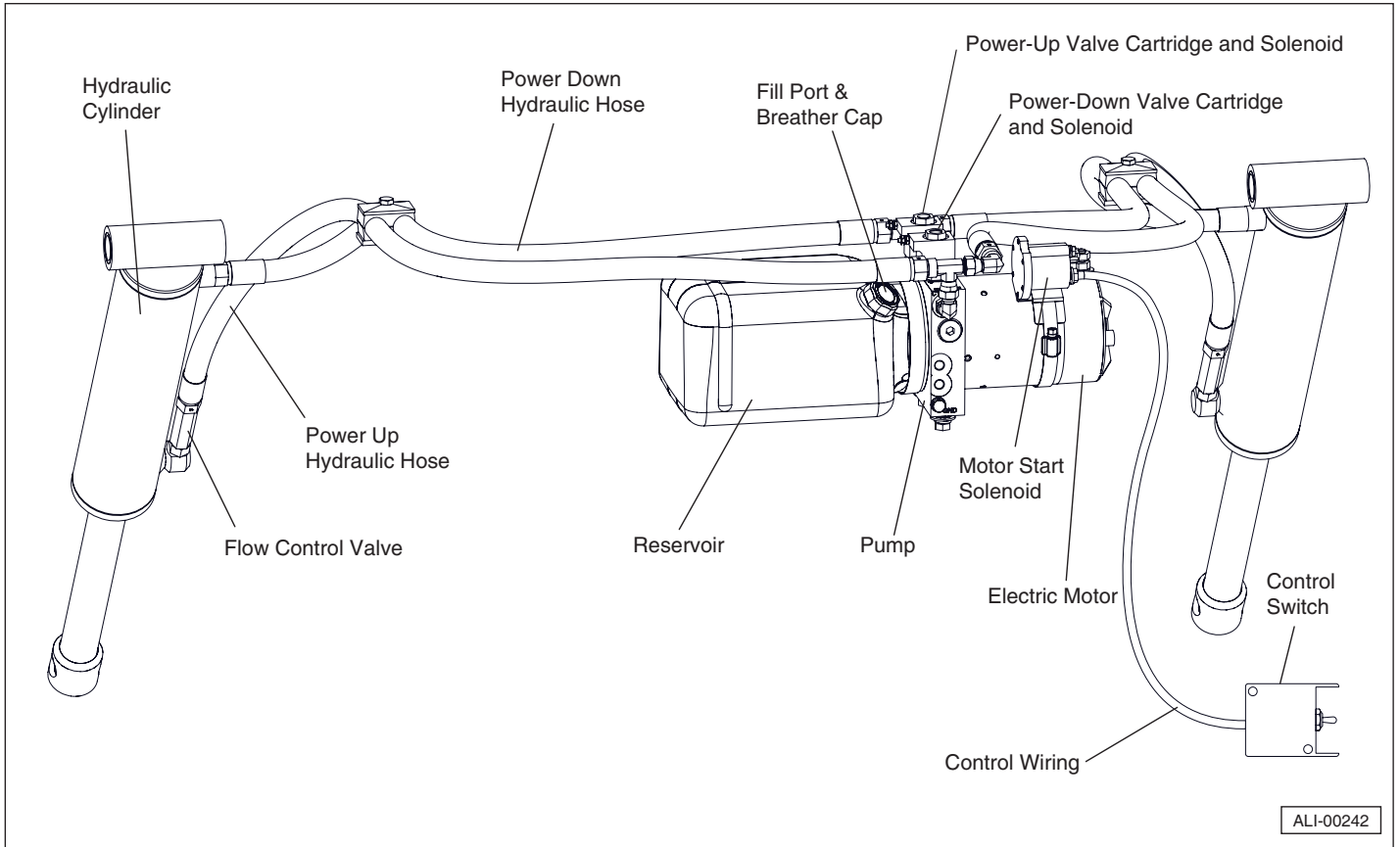

4. Installation Section

If tools, procedures, work methods, or operating techniques that are not specifically mentioned by Anthony Liftgates are used, you must satisfy yourself that they are safe for you and for others. Make sure the liftgate or truck it is mounted onto will not be damaged or made unsafe by any operation, lubrication, maintenance, or repair procedures that you choose.



DO NOT proceed if any doubt arises about the correct or safe method of performing anything found in this or other Anthony Liftgates' manuals. Seek out expert assistance from a qualified person before continuing.

4.1 Installers Safety

 **WARNING**    To prevent serious bodily injury, keep sparks, lighted matches, and open flames away from the top of the battery, because battery gas can explode. Always follow all the manufacturers' safety recommendations when working around the truck's battery.



 Take precautions to avoid sparks coming into contact with the truck's fuel tank, brake lines, or other flammable components. Sparks can cause an explosion of combustible materials, resulting in serious injury or death.

 Never secure the power cable to anything which allows it to contact sharp edges, other wiring, fuel tank, fuel lines, brake lines, air lines, exhaust system, or any other object that could cause the power cable to wear or be damaged. A cut battery cable can cause sparks resulting in loss of vehicle control, serious injury, or even death.

   Always weld in a well ventilated area and, if in an enclosed area, vent the fumes to the outside. Breathing welding smoke and paint fumes can cause serious injury.

 Always follow all State and Federal health and safety laws and/or local regulations when using an arc welder, mig welder, or cutting torch. Also, follow all manufacturer's safety guidelines. If other people are present during the installation of the liftgate, make sure the welding area is shielded from their view.

 To avoid eye injury during welding, always wear a welding helmet with the proper lens to protect your eyes.

  To prevent personal injury, clean up any spilled fluids immediately. To avoid tripping, do not leave tools or components laying around in the work area.

 Failure to prevent the truck from moving during the installation of the liftgate could result in a serious crushing injury.



Do not work under the liftgate while it is suspended from the lifting equipment. Failure of the lifting equipment could cause serious crushing injuries. Do not remove the lifting equipment until the liftgate is completely welded onto the truck frame.

SAFETY INSTRUCTIONS



To prevent injury, the liftgate and its related components should only be installed by a qualified installer who has knowledge and skill in using welding equipment and a cutting torch.



To prevent possible injuries due to improper operation, make sure all decals are attached to the liftgate and/or truck and are legible at all times.

4.2 Tools Required

The following is a list of suggested tools that should be used to install the liftgate:

- Band Cutters
- Overhead Crane or Forklift
- Mig or Stick Welder
- Heavy-Duty C-Clamps
- Tape Measure
- Level (small, magnetic)
- Cutting Torch (in some applications)
- Wrenches (bolt-on models only)
- Grinder (removing galvanized surface before welding)
- 1/2 inch Impact Wrench (bolt-on floor extension)
- Heat Gun or Propane Torch for Shrink Tube (cable lug)
- Crimping Tool (cable lug)

4.3 Bed Height and Clearance Requirements

NOTICE

To prevent damage to the truck and/or the liftgate, make sure the model being installed is compatible with the bed height of the truck.

1. Place the truck on a flat, level surface with the parking brake set.

WARNING



Failure to prevent the truck from moving during the installation of the liftgate could result in serious personal injury or death.

SAFETY INSTRUCTIONS

Remove the keys to prevent unwanted movement.

2. Be aware that as part of the installation preparation, the liftgate will not operate properly if the truck bed height falls beneath dimension (A). This reduced height can be the result of a fully loaded truck and/or a variety of other reasons. Do not proceed if the truck will not meet the minimum height requirement.

Truck Bed Height Fully Loaded		
Model	Bed Height (A)	
	50" Platform	60" Platform
DCT-25	42"	47"
DCT-33	42"	47"

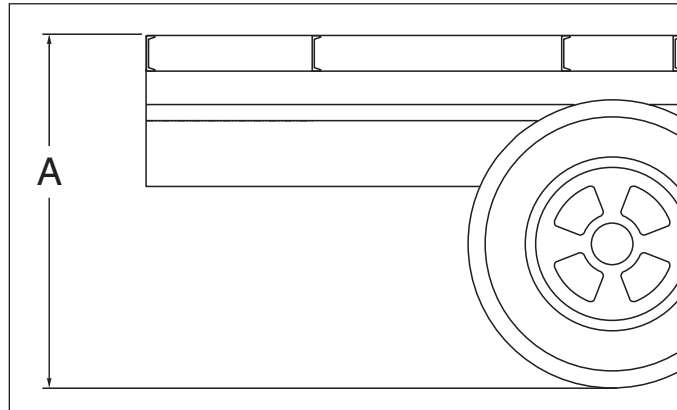

3. Measure the actual height of the unloaded truck, which must be equal to or less than dimension A (maximum height). Do not proceed if this dimension does not fall within the maximum height requirements.

Truck Bed Height Unloaded	
Model	Bed Height (A)
DCT-25	57"
DCT-33	57"

4. Use the following illustration and chart to ensure there is no interference between the liftgate and truck frame, in the area of dimensions B and C, which would prevent proper installation.

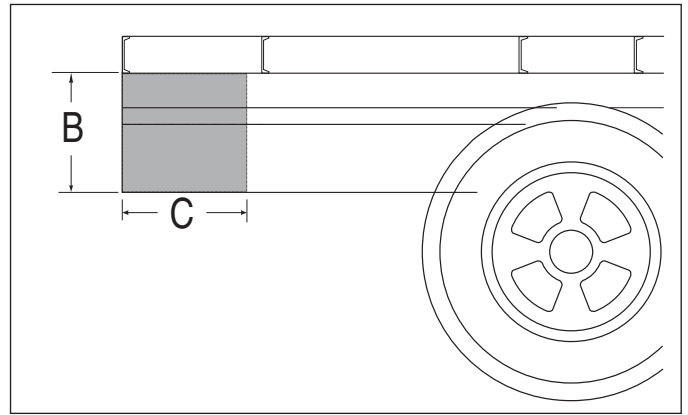

Note: The dimensions in the following chart are only a guide for required clearances.

Mounting Clearance Requirements		
Bed Height (floor surface)	B Floor Surface to Bottom of Truck Frame (minimum)	C Distance with No Obstructions
42" - 49"	19"	24-1/4"
50" - 51"	20"	23-3/4"
52" - 53"	21"	23-1/4"
54" - 55"	22"	22-5/8"
56" - 57"	23"	22-1/2"

4.3.1 Preparation

SAFETY INSTRUCTIONS



Use two people to safely install the liftgate.

NOTICE

Check the OEM vehicle manual for any special requirements prior to welding on the truck's frame. If required, disconnect the battery cable before welding on the truck frame.

1. Remove the banding securing the liftgate and loose parts to the pallet. Remove the curbside and streetside mounting plates, the floor extension, the dock bumpers, and the side gussets from the liftgate frame.



ALI-00001

2. Before proceeding, make sure the complete liftgate and its related parts have been received, as listed in the chart below. In some cases, related installation parts will be located on the shipping pallet or they may be shipped separately. Some parts are also placed inside the pump box.

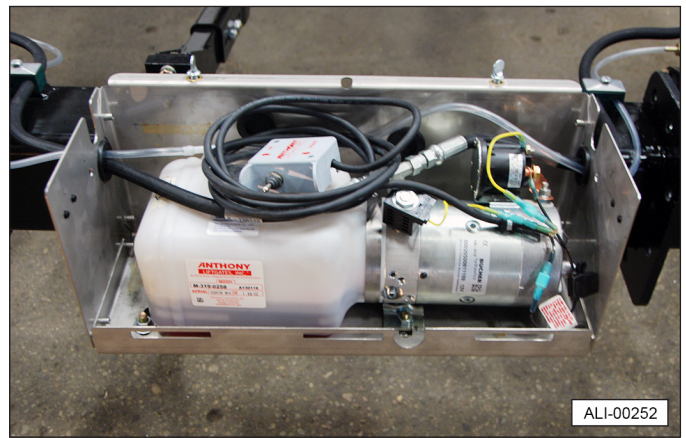

Note: The power unit box should contain the power cable and switch, plastic tie wraps for the battery cable, and one package containing decals, shims, a 200 Amp fuse, and manuals.



4. Carefully unfold the liftgate using two people. To keep the liftgate somewhat level once it's unfolded, a wooden block, approximately 12 inches tall, can be placed under the platform.

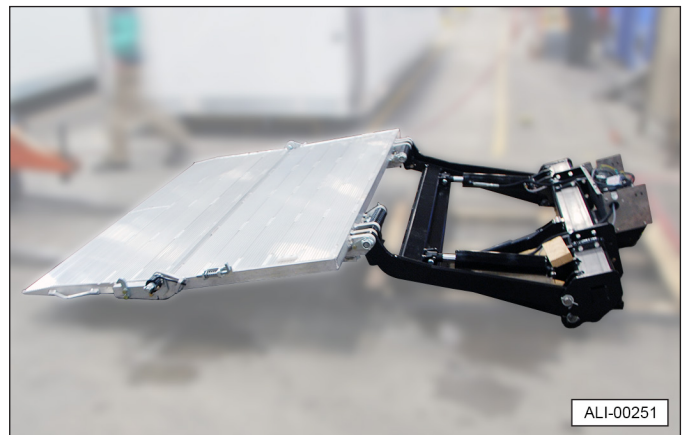

Liftgate Installation Package	
Description	Qty.
Located on Pallet	
Floor Extension	1
Streetside Step and Dock Bumper Assembly	1
Curbside Step and Dock Bumper Assembly	1
Streetside Mounting Plate	1
Curbside Mounting Plate	1
Power Cable with 200 Amp Fuse	1
Located Inside Pump Box	
Information Packet (contains decals, manuals, shims, and other related installation information)	1
Plastic Tie Wraps	-

3. Remove the cover from the power unit box. Remove all loose parts for the assembly process and the instructions from inside the box. Replace the plug in the power unit reservoir with the supplied breather cap.

Note: A spacing guide is installed over the end of the cylinder rod. Do not remove this guide until the liftgate has been tack welded in place on the truck body.

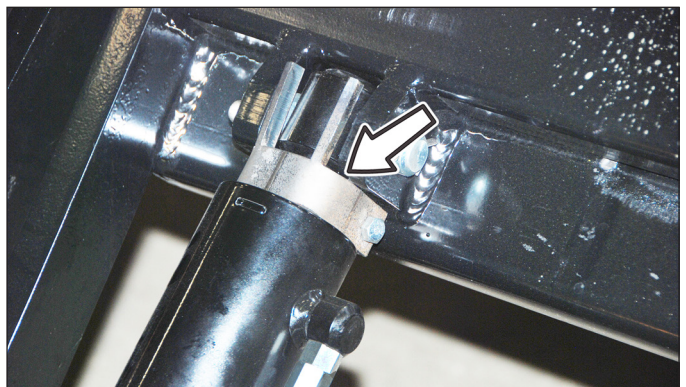

5. If necessary for liftgate clearance, cut the chassis frame and body long sill, as shown in the following illustration. After making the cut, make sure the liftgate operates properly without interfering with the chassis frame or body long sill.

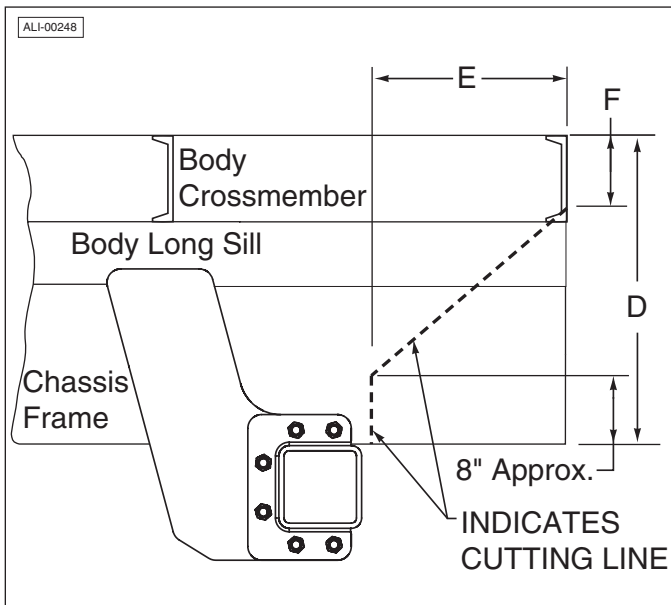

Chassis Frame Length			
Bed Height	D	E	F
42" - 43"	17"	14-3/4"	4-1/4"
44" - 50"	18"	14-1/4"	5-1/8"
51" - 53"	19"	13-3/4"	5-3/4"
54" - 55"	21"	13-1/2"	6"
56" - 57"	23"	13-1/8"	6-1/4"

Note: The dimensions in the chart are only to be used as a guide for what can be expected for clearances needed. They DO NOT have to be exact, unless you are near the extreme high or low-end of the bed height mounting range.

Note: Once the liftgate is installed, make sure it will operate properly, without interfering with the truck frame or the body long sill.

4.3.2 Installing Floor Extension



If a galvanized floor extension and dock bumpers are being installed, the galvanized material must be removed prior to welding.

There is also a special procedure to follow when welding galvanized material to a stainless steel truck body sill.

Follow all OSHA and other workplace safety standards when grinding or welding galvanized steel, which creates zinc oxide fumes. Always grind the coating off in the area to be welded and provide adequate ventilation to avoid breathing the fumes.

Always wear the proper breathing protection when grinding or welding. Use a ventilation or vacuum system to remove any contaminated air from the work area.

This procedure is for welding the floor extension to the truck body. If a bolt-on method is preferred, refer to section "4.6 Bolt-On Floor Extension" on page 28 for the complete procedure.

1. If desired, spray the parts of the truck body near the areas to be welded with anti-splatter spray.



2. Find and mark the center of the truck's rear sill and the center of the floor extension with a white marker.

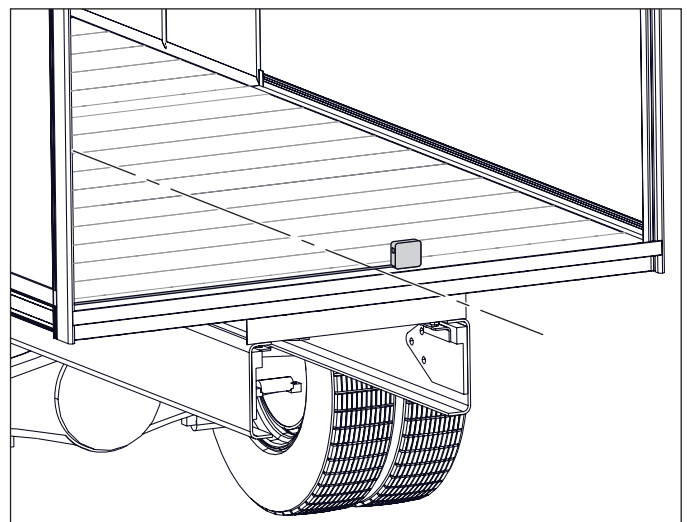

3. Install the floor extension.

- a. Use a white marker to also mark the finish weld locations with a repeating 2 inch continuous weld with a 4 inch gap. Make your marks from both ends inward toward the middle.
- b. Using a lifting device, center the white mark on the floor extension with the white mark on the truck body.

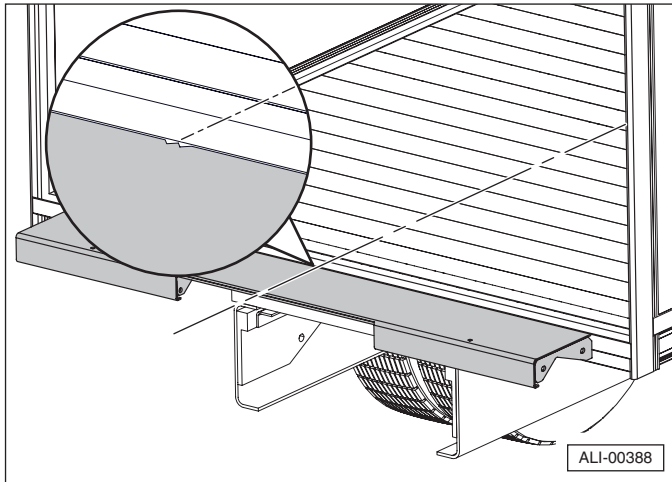

- c. With the center of the floor extension level with the floor of the truck, begin tack welding at the center and work outward. Make sure the extension remains level and flush with the floor of the truck bed.

Note: The floor extension has a natural bow in it and must be straightened as it is installed.



Tack welds must be strong enough to hold the weight of the floor extension (up to 300 lbs.) until the final welds are completed. Insufficient welds may not hold the floor extension, resulting in possible bodily harm.

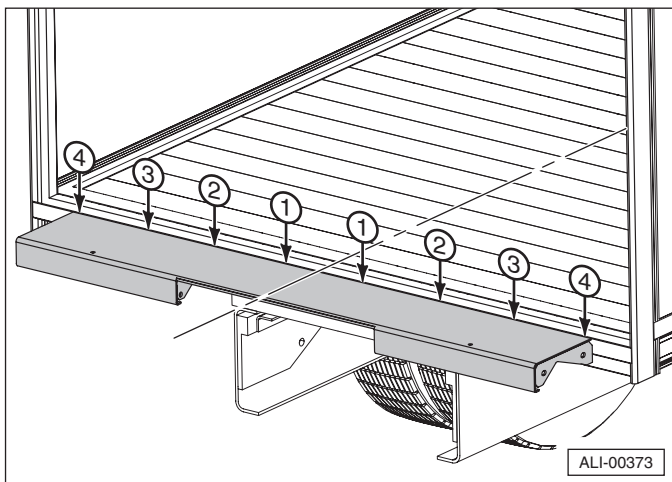

- d. Also, make sure the floor extension is level and parallel to the truck's rear sill.

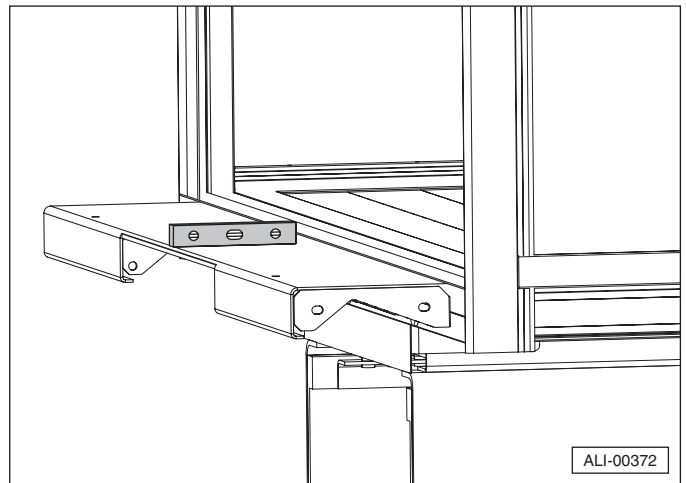

- 4. Tack weld both the streetside and curbside dock bumpers onto the floor extension.

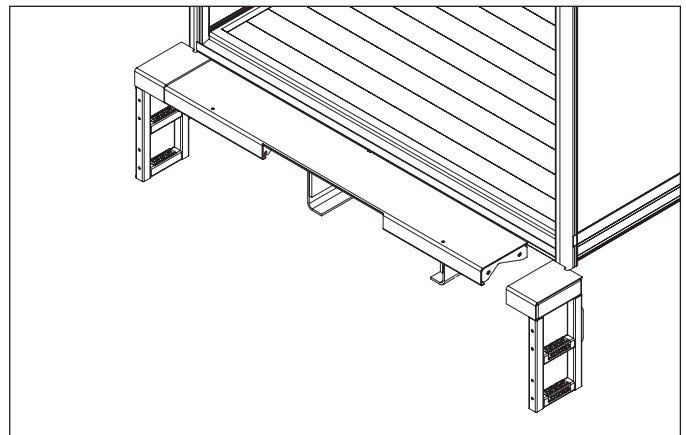

- e. Once you have verified the floor extension is straight and level, finish welding it to the sill of the truck body with 2 inch long welds, every 4 inches.

Weld the dock bumpers to the floor extension and the truck body sill using a continuous weld.

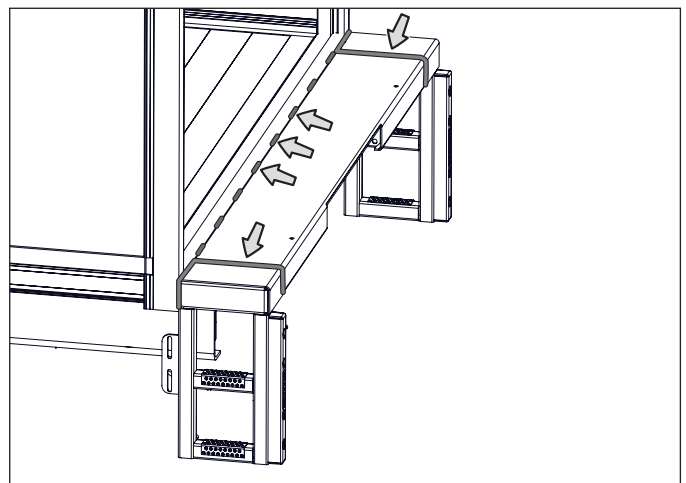

- f. Weld across the bottom of the floor extension in seven to eight locations.

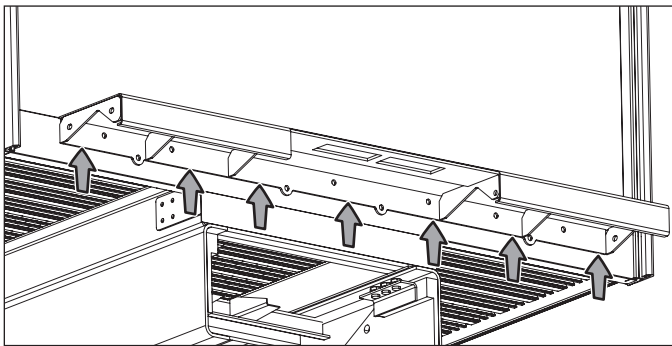

- g. If a walk ramp floor extension is being installed, weld both sides of the support gussets to the truck body sill.

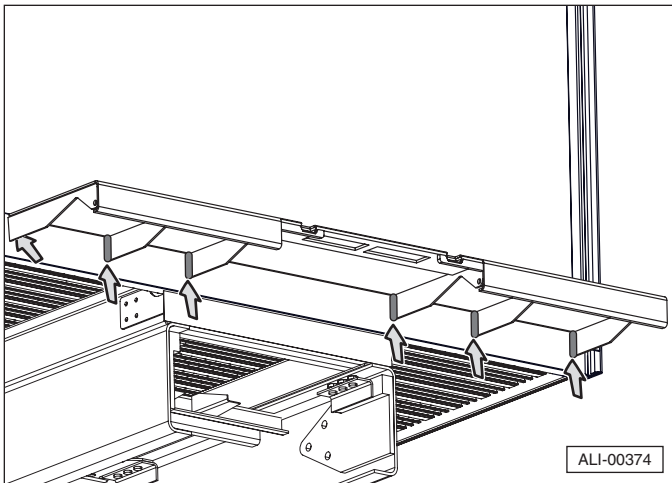

5. Weld and/or bolt the side gussets to the dock bumper and the truck body. If welding to the truck body crossmembers, make sure it spans at least three of them.

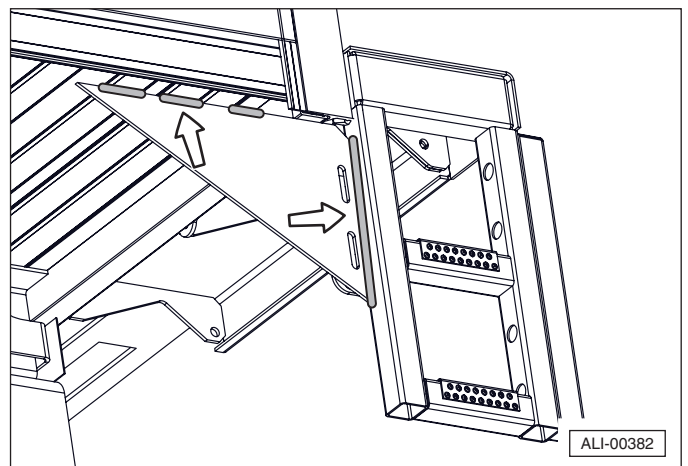
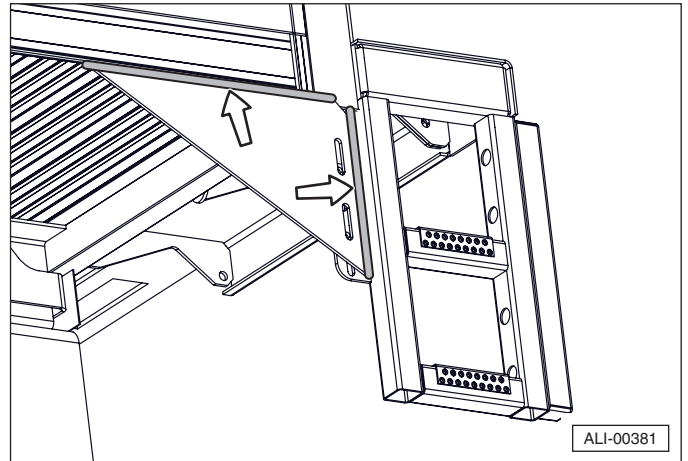

- h. If not already installed, weld several installer-supplied strengthening plates between the crossmembers and the truck body sill.



4.3.3 Adjust Width of Mounting Plates

1. Measure the outside width of the truck chassis frame rails. This dimension must be the same, or no more than a 1/4" less than the inside dimension of the mounting plates. It must not be larger.
2. The mounting plates are factory installed on the liftgate with an inside spacing of 34-1/4". This will work for most trucks, however, four 1/4" spacers are included to adjust the width if necessary.

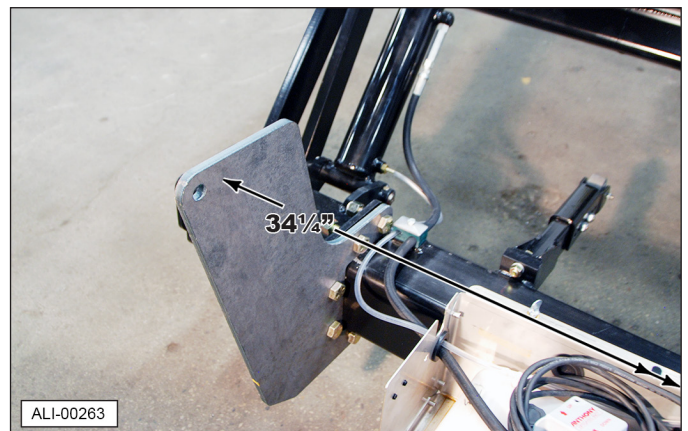



3. To adjust the width, remove the six bolts and nuts from each mounting plate. Add or remove spacers to achieve the desired width, and replace the bolts and nuts. Be sure to make the same adjustment on both sides to keep the liftgate centered.

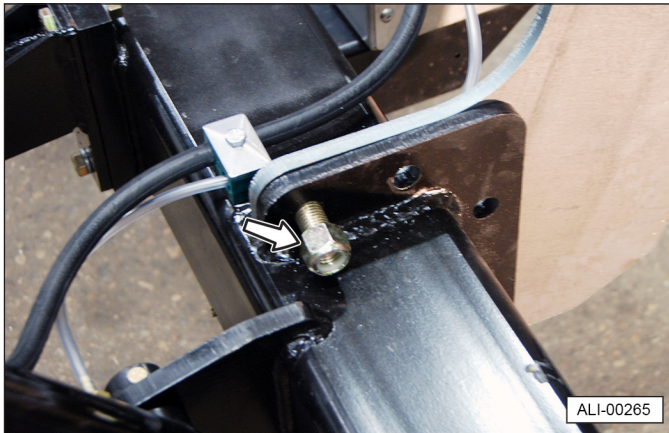

4.3.4 Positioning the Liftgate

Use a forklift or overhead lifting device to lift the liftgate. If using a forklift, the use of a lifting fixture makes the installation process easier and safer.

Note: Refer to “5. Lifting Device” on page 30 for a dimensional drawing to fabricate the lifting fixture.



Do not work under the liftgate while it is suspended from the lifting device.

The liftgate can weigh up to 1,100 lbs. and failure of the lifting device could cause serious crushing injuries.

1. For steel platform liftgates:
 - a. Place the lifting fixture over the liftgate.
 - b. Place the threaded rod through the lifting hole in the platform.
 - c. Install a washer and nut on the threaded rod.

- d. Raise the liftgate, making sure the platform is almost parallel with the ground. Use the threaded rod and nut to make the required leveling adjustments.



2. For aluminum platform liftgates:
 - a. Place the lifting fixture over the liftgate.
 - b. Place chains or a lifting strap around the lifting fixture and the platform.

NOTICE To prevent damage to the liftgate, use wood or other protective material between the lifting chain/strap and the platform to prevent surface damage.

- c. Adjust the chains/strap until the liftgate is almost parallel with the ground.

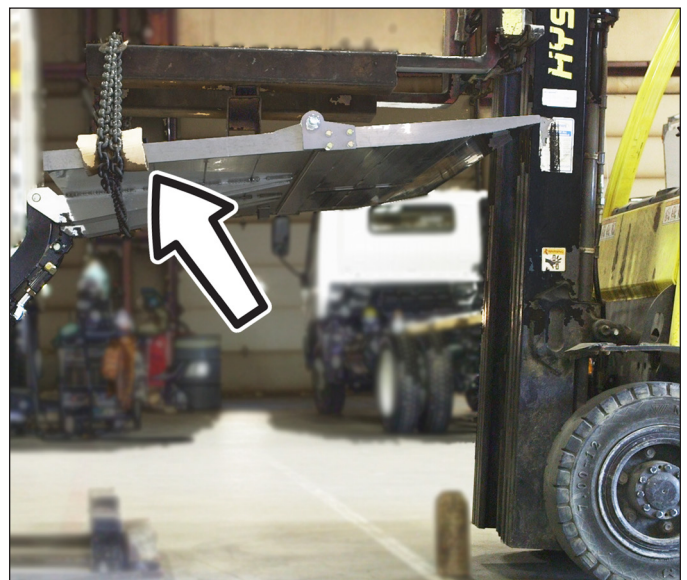

4.3.5 Attaching Liftgate to Truck Frame

1. Raise and position the liftgate against the platform installation brackets (arrows), which are attached to the floor extension. Also, push the liftgate against the spacer portion of the installation brackets.

WARNING



Do not work under the liftgate while it is suspended from the lifting device.

Failure of the lifting device could cause serious crushing injuries. Do not remove the lifting device(s) until the liftgate is securely tack welded to the truck frame.

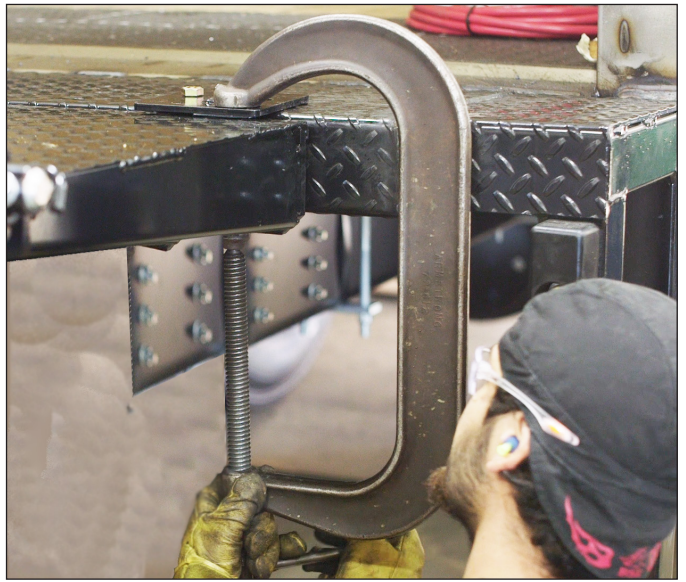

3. Place a lifting device (floor jack shown) under the wheel arm, as shown.

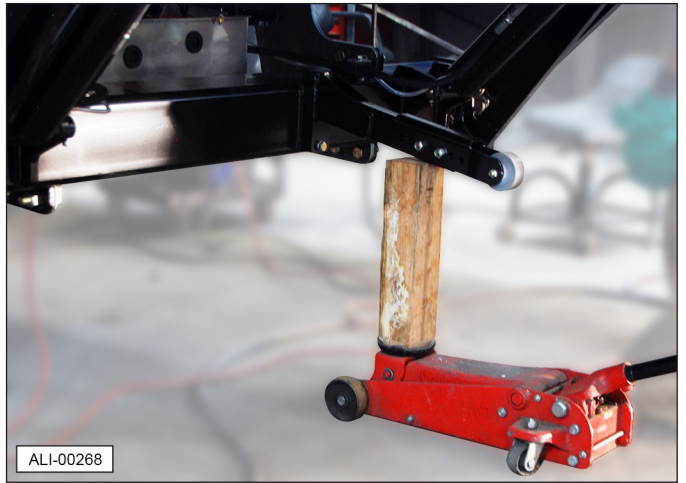
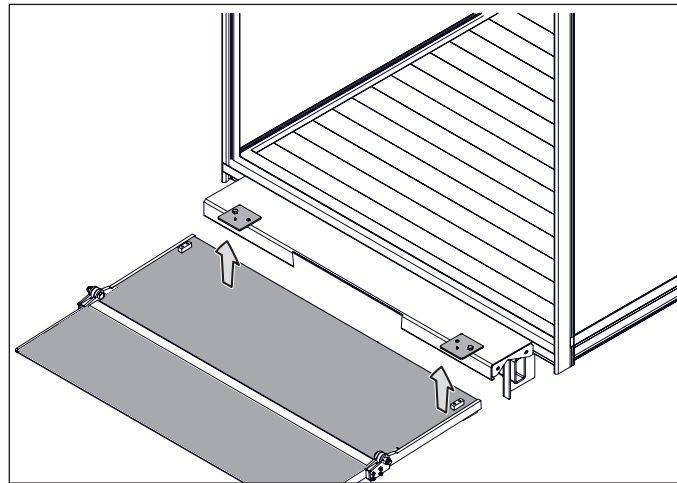

4. Determine the installed height (B) of the adapter frame tube using the charts and the illustration.

2. Clamp the liftgate against the floor extension using two large C-clamps, as shown.

NOTICE

If the liftgate has an aluminum platform, use wood or other protective material to prevent surface damage.

surface damage.

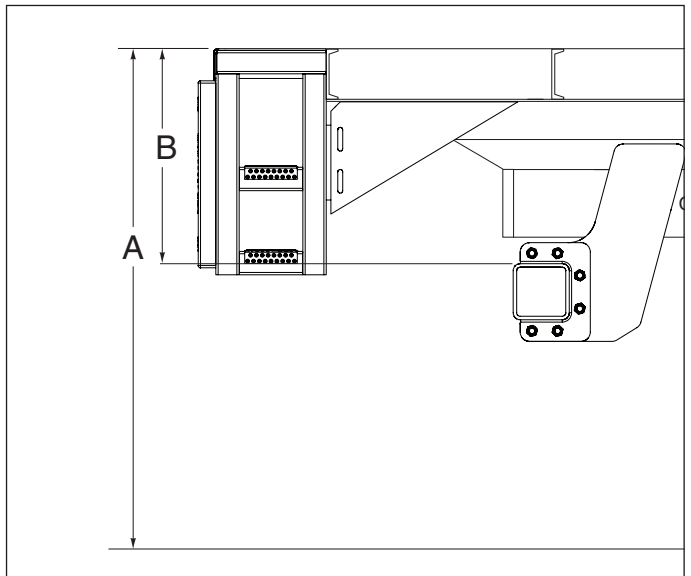

Refer to the Mounting Requirements chart for dimensions.

Mounting Requirements for 50" Platform		
A Bed Height Floor Extension	50" Aluminum Platform	50" Steel Platform
	B Bed to Top of Tube Assembly	
42" - 43"	17"	17"
44" - 49"	18"	17"
50" - 52"	19"	18"
53"	19"	19"
54"	20"	20"
55"	21"	21"
56"	22"	22"
57"	23"	23"

Mounting Requirements for 60" Platform		
A Bed Height Floor Extension	60" Aluminum Platform	60" Steel Platform
	B Bed to Top of Tube Assembly	
46" - 47"	18"	18"
48" - 49"	19"	19"
50" - 52"	18"	18"
53"	19"	18"
54"	20"	19"
55"	21"	20"
56"	22"	21"
57"	23"	22"

Note: In some cases, the top of the adapter frame tube may be against the frame or could be above the frame. It may be necessary to notch the frame in order to achieve the required height of the adapter tube frame.

5. Raise the adapter frame tube to the correct height of dimension (B), which is based on the height of the truck bed.

NOTICE

Do not bend the wheel arm during the leveling process.

If the adapter frame tube does not easily raise, it may be necessary to actuate the control valve to release hydraulic pressure in the cylinder if the adapter frame tube will not raise completely.

6. To actuate the control valve, it's necessary to connect a 12 Volt slave battery to the motor start solenoid.

Connect the red jumper cable from a 12 Volt slave battery to the positive (+) terminal of the motor start solenoid. Connect the black (-) cable to a ground on the pump box.

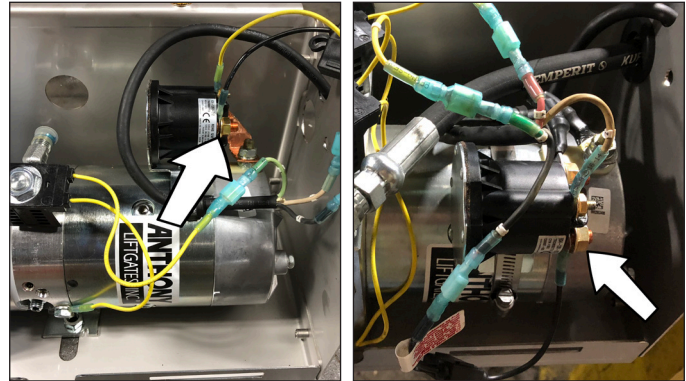
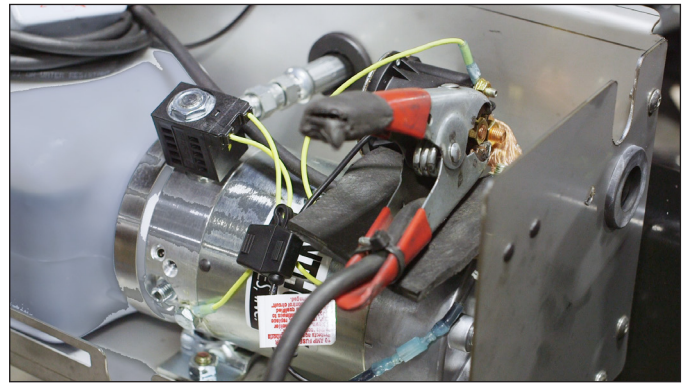

7. For gravity-down models, simply press and hold the control switch in the DOWN position to release the pressure in the cylinder.

For power-down models, briefly press and release the control switch in the UP position. Remember that pressing the UP control will hydraulically raise the adapter frame tube.

Once the adapter frame tube is at the proper height, the top of the tube should be slightly angled toward the back of the truck.

8. Tack weld the mounting plates to the frame in the locations marked "X" (each tack weld should be a 3/8 inch fillet, 1 inch long).

Note: Do not fully weld the mounting plates to the chassis frame at this time.

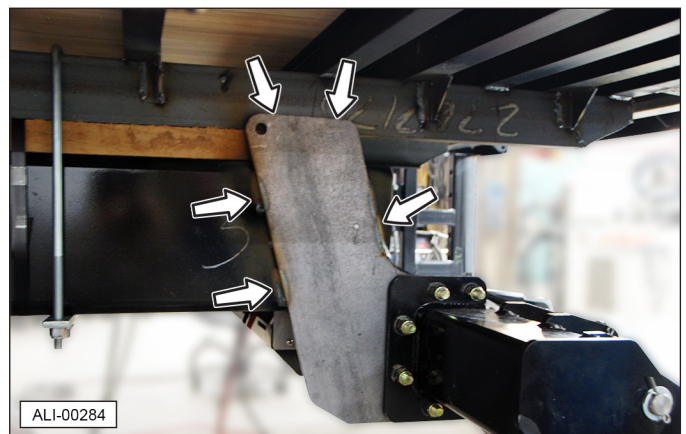



The tack welds must be strong enough to hold the weight of the liftgate, which can be up to 1,100 lbs. Insufficient welds may not hold the liftgate in place, resulting in possible bodily harm.

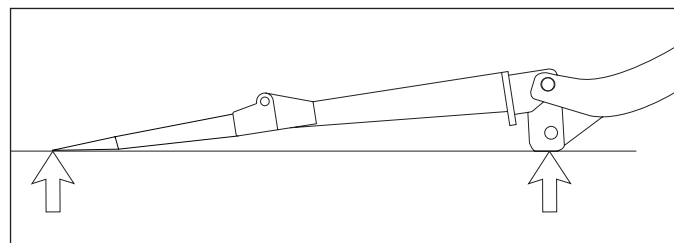

9. Remove the floor jack.
10. Press the UP control to raise the platform. Raising the platform prevents it from slightly lowering when the clamps are removed.
11. Remove the C-clamps and the lifting device.
12. Make sure the latch pin is in the open position.
13. Standing on the curbside of the truck, away from the platform, actuate the DOWN switch to lower the platform to the ground.

16. Completely raise the platform.

The outboard edge of the flip-over section should be 1 to 1-1/2 inches higher than the platform section, as shown, when correctly installed.

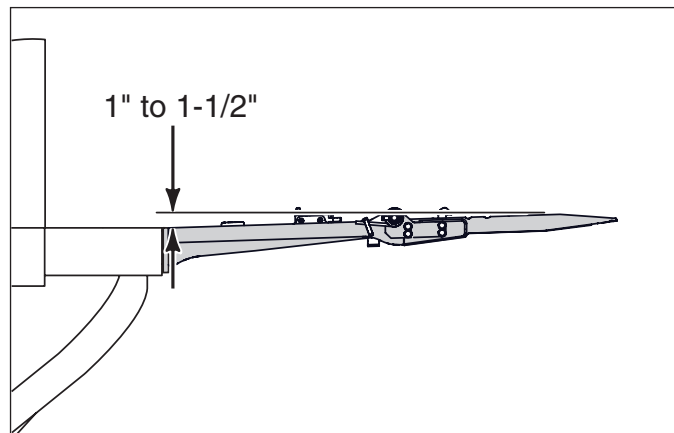
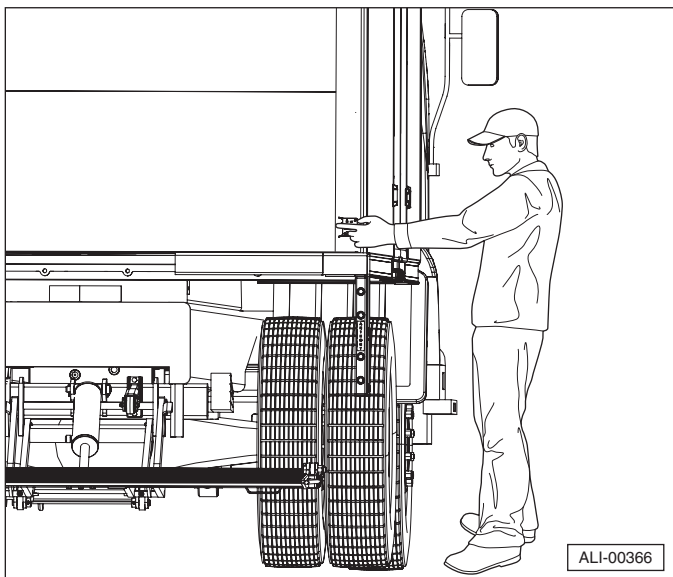

17. If the end of the platform does not contact the ground, adding a shim to the stop block will raise the outboard end of the flip-over section.

Removing material from the stop blocks will lower the outboard end of the flip-over section.

14. Remove the spacing guide from the lift cylinders.

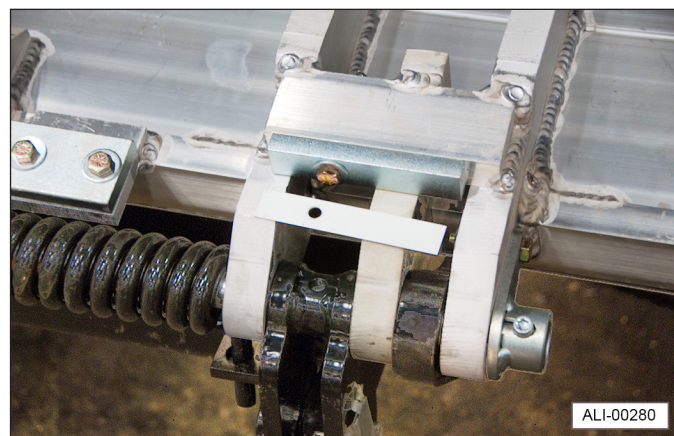
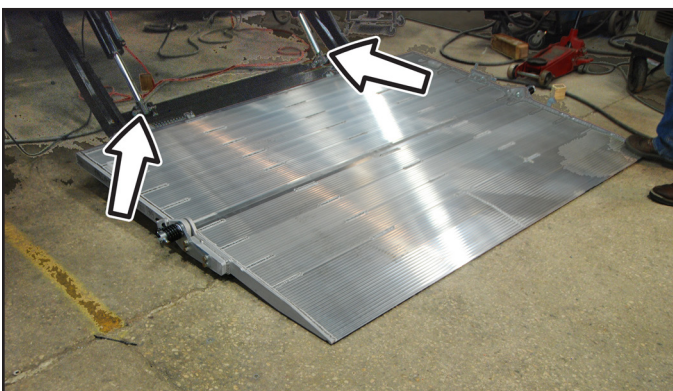

Note: One shim can move the ramp end of the platform as much as 1/2 inch.

15. The front edge of the flip-over platform section should lower to the ground and contact the ground at the points as shown, and the back of the platform should raise flush to the floor extension. If the front edge does not touch the ground, refer to the next step.

18. If the platform is operating correctly, finish welding the mounting plates. If the platform does not make a complete cycle, adjust the mounting plates, as necessary.
19. Cover the cylinder, cylinder rod, and pump box to prevent damage from weld spatter.



Take precautions to avoid welding sparks coming into contact with the truck

bed's wooden floor or other flammable components.



For safety purposes, finish welding the liftgate while the platform is on the ground, not in

a raised position.



Cover the cylinder rod to prevent weld spatter from damaging it.

20. With the liftgate on the ground, completely weld the mounting plates onto the truck frame with a continuous weld. Weld on both sides of the mounting plates wherever possible.



21. Remove the installation brackets from the floor extension.

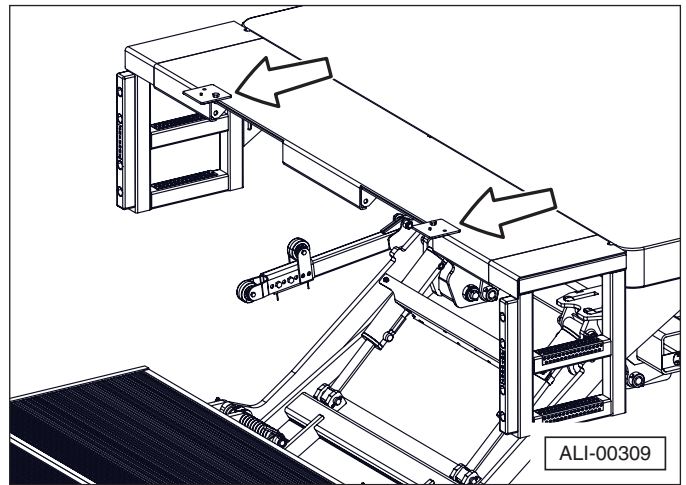

4.3.6 Installing Optional DOT Tubular Bumper

1. If desired, install the optional tubular bumper using the supplied hardware. Make sure the installation is in compliance with all State and Federal regulations.

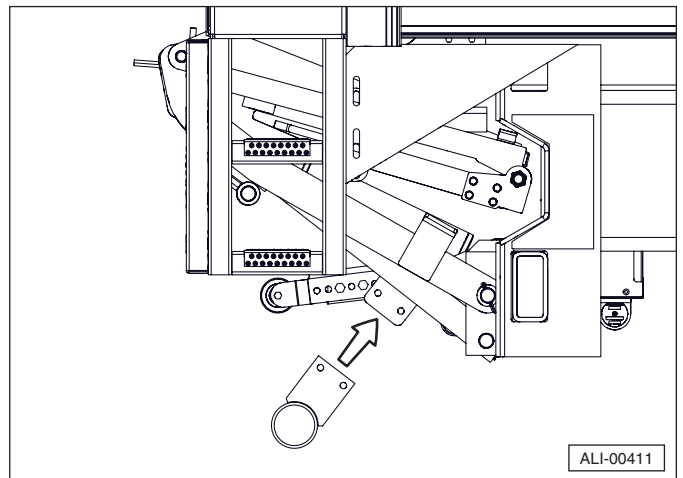

2. With the liftgate in the stored position, attach the red and white reflective tape.



4.3.7 Mounting Control Switch and Routing the Power Cable

1. Remove the slave battery's jumper cables and disconnect the wires of the control switch from the power unit.
2. Using a 3/8" hex bolt, attach the ground cable to the driver's side mounting plate. Attach the other end to one of the power unit box and pump housing bolts.

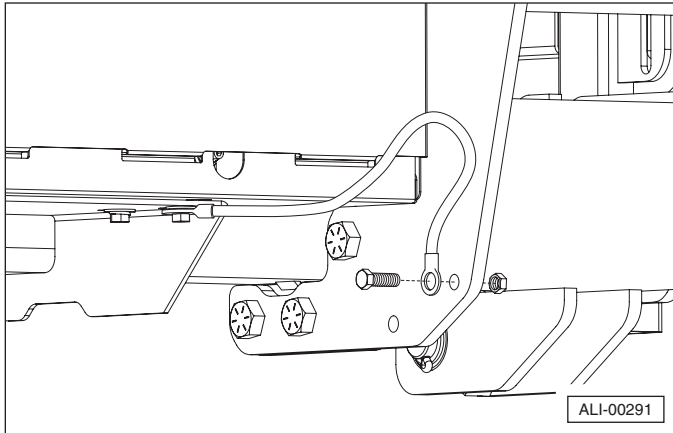

NOTICE Do not omit the ground strap. A proper ground connection is crucial to the life of the liftgate's power unit. A poor ground connection can result in low voltage, and any attempt to operate below the minimum required voltage could cause system failure.

3. Mount the control switch to the truck's rear curbside post, so it can be reached while standing at the curbside of the truck, away from the liftgate platform.

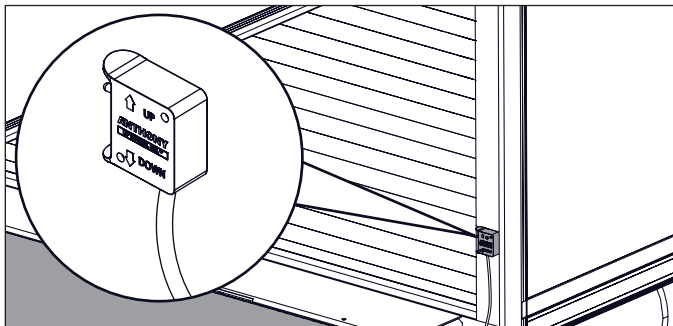

4. Disconnect the wires of the control switch from the power unit.
5. Install the protective rubber grommet in the dock bumper and route the wire through the dock bumper.

6. Reattach the control unit wires to the appropriate terminals, as shown.

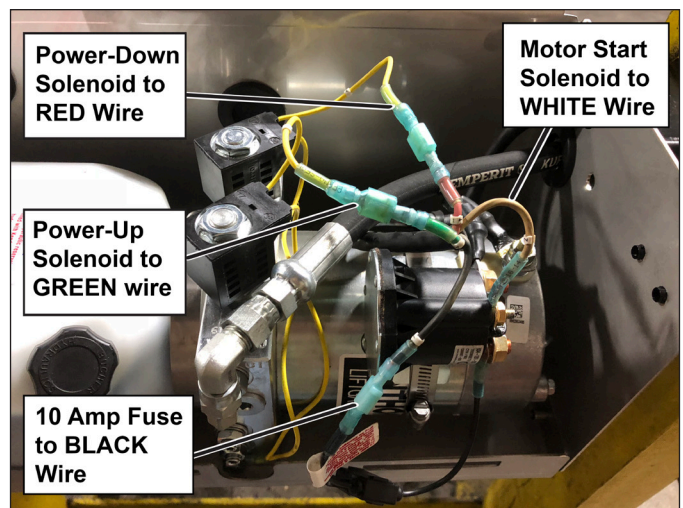
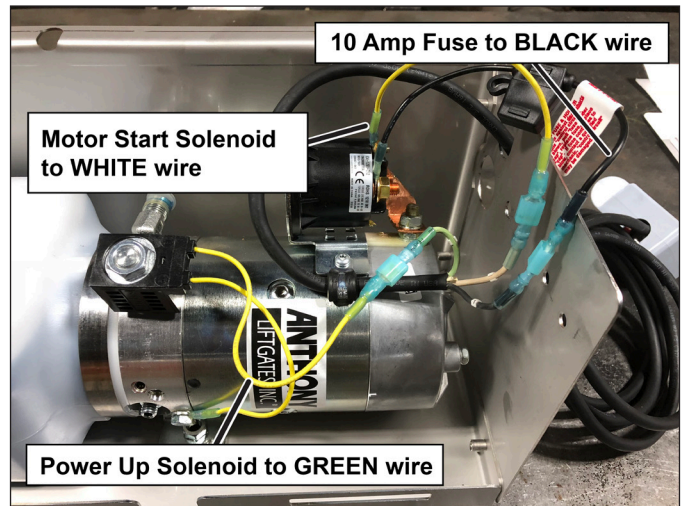

7. Connect the long section of the power cable to the motor start solenoid.

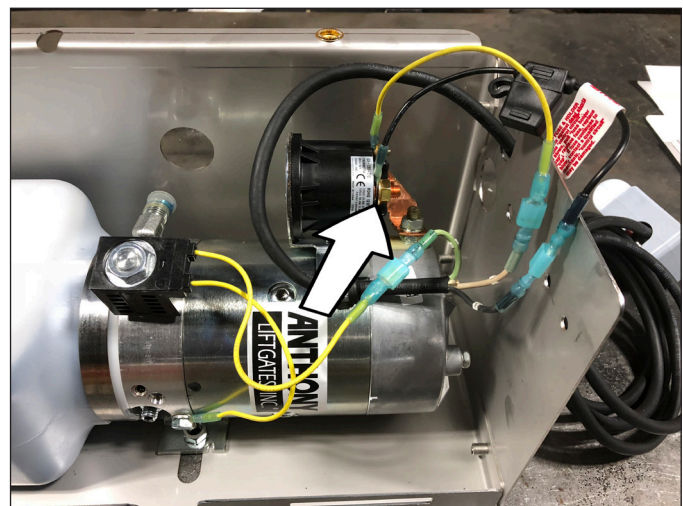

Connection for gravity down models.

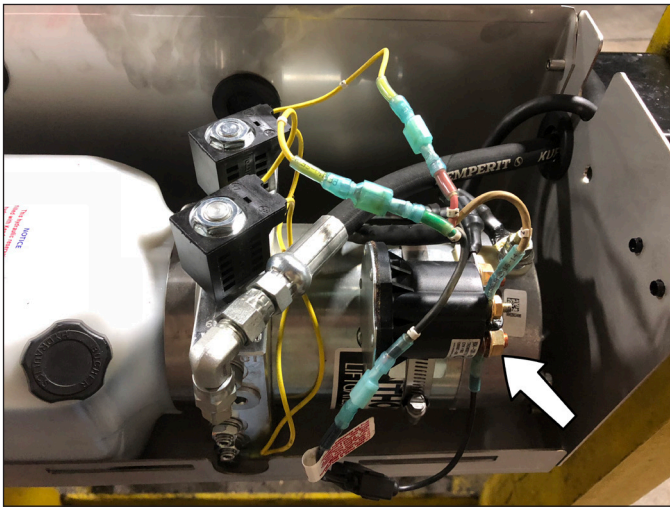

Connection for power down models.

WARNING  Improper grounding can cause an electrical current to travel through brake lines, steel braided power steering hoses, or other truck frame components, causing failure to these components, which could result in the loss of vehicle control.

8. If needed, attach a ground strap, the same gauge or larger as the liftgate power cable, between the pump box and the truck frame.

WARNING  Never secure the power cable to anything which allows it to contact sharp edges, other wiring, the fuel tank, fuel lines, brake lines, air lines, exhaust system, or any other object that could cause the power cable to wear or be damaged. A cut battery cable can cause sparks, resulting in the loss of vehicle control, serious injury, or even death.

9. Route the power cable along the truck frame to the battery box, attaching it with plastic tie wraps or wire clips. If the cable is too long, cut it to the desired length.

10. Install the optional cut-off solenoid or cut-off switch, if desired.

WARNING  Anthony Liftgates strongly recommends the installation of an optional power cut-off solenoid (“4.4 Cut-Off Solenoid Connection” on page 27) or cab cut-off switch (“4.5 Cut-Off Switch Connection” on page 27). Allowing power to the liftgate when the truck is unattended can result in serious injury or death.

11. Reconnect the newly-cut end to the fuse.

12. If the power cable requires a cable lug on the end, follow these steps.

- a. Strip the insulation one inch back from the end of the cable to expose the copper wire.

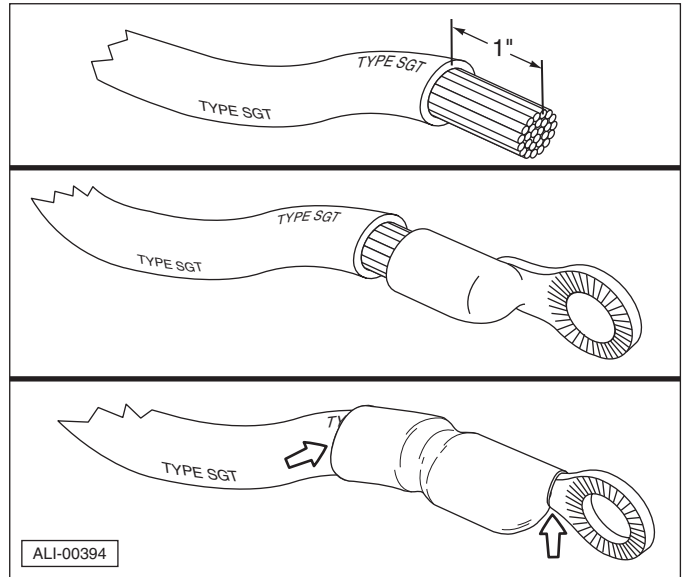

- b. Position the cable lug on the exposed wire, as shown. Crimp the cable lug using a cable crimping tool (hydraulic or manual).
- c. Use the supplied heat shrink tube to insulate the new connection, leaving only the mounting hole exposed.

NOTICE *Proper wire connection is crucial to liftgate’s electrical components. A poor connection can result in low Voltage, causing the liftgate to work improperly. DO NOT crimp (smash) the cable lug with a hammer to secure it to the cable.*

13. Mount the fuse in a desired location.

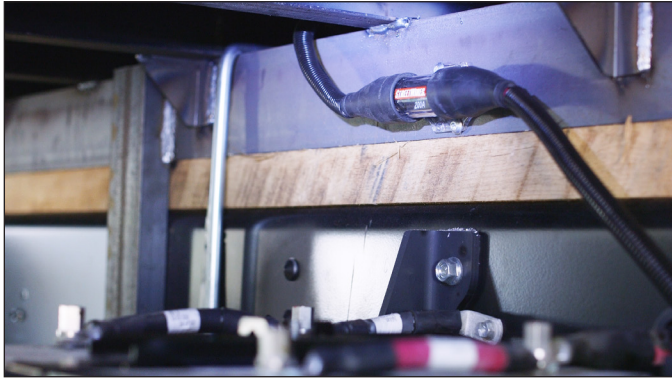

14. Route the short, 3 foot section of cable into the battery box and connect the end to the positive (+) post of the truck battery.

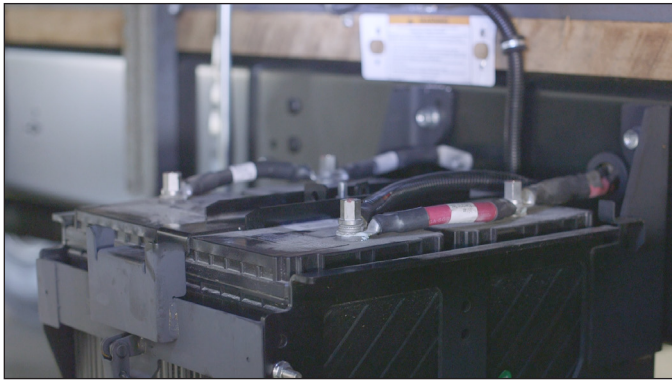

15. Use the control switch to raise and lower the platform.

16. Coat any terminal ends, studs, and nuts in the liftgate electrical system with a suitable corrosion-inhibiting lubricant.



17. Replace the battery box cover and lock it in place.

NOTICE

Do not apply petroleum-based lubricant to the liftgate motor start solenoid. Use only a dry film lubricant on this component.

4.3.8 Adjust the Wheel Arm

The wheel arm helps unfold the platform as it is lowered from the stored position. The wheel arm can be adjusted so the platform unfolds with either greater or lesser effort.



Never stand behind the liftgate when it is opened. Always stand to the side and away from the edge of the platform.

When adjusting the position of the wheel arm, consider that the vehicle may be parked on an upward, sloped surface. Adjust the wheel arm to prevent the platform from completely unfolding in this type of situation.

1. If adjustment is needed, remove the two bolts on the wheel arm and the nuts on the wheel arm.
2. Lengthen or shorten the wheel and channel assembly on the tube, as desired.

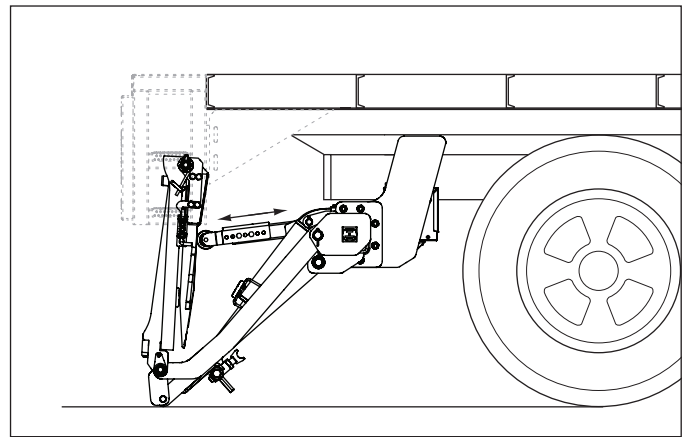

3. Align the two holes in the wheel and channel assembly with the holes in the tube nearest the desired position.
4. Re-install the two bolts and nuts. Tighten the nuts to secure the wheel and channel assembly.

4.3.9 Adjust Latch Pin

1. Adjust the latch pin plate allowing a 1/16 to 1/8 inch gap between the latch plate and the latch pin. Insufficient clearance can allow binding of the latch pin as the liftgate is used, while too much clearance will not properly secure the liftgate. If the latch pin will not easily open, press the UP control button to release any tension on the latch pin.

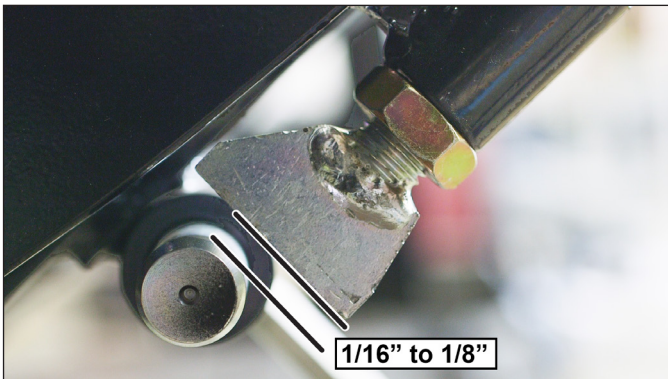
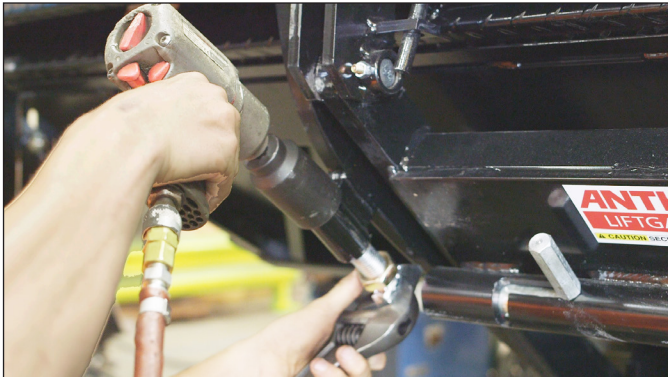

4.3.10 Installing DOT Lighting, Decals, and Any Components Not Part of Liftgate

1. Install DOT lighting or other electrical components.
2. Install the license plate bracket.
3. If required, install grab bars or hand rails.

NOTICE

Most liftgates have built-in steps to assist in ingress/egress of the platform. These steps are NOT to be considered all-inclusive of any requirements or guidelines regarding proper ingress or egress. It is the installer's responsibility to determine the proper requirements, such as steps, hand grips, grab bars, etc.

4. Attach all decals, as shown in section "7. Decals" on page 32.
5. Make a final operation check. Refer to section "4.3.11 Final Inspection Checklist" on page 26.

NOTICE

The latch pin is only for in-transit locking of the liftgate. DO NOT slide the latch pin into the latched position when the platform is unfolded and raised. If this occurs, serious damage to the liftgate can occur when the liftgate is lowered.

6. Raise the liftgate to the stored position and operate the latch to make sure the latch pin moves freely and engages properly.

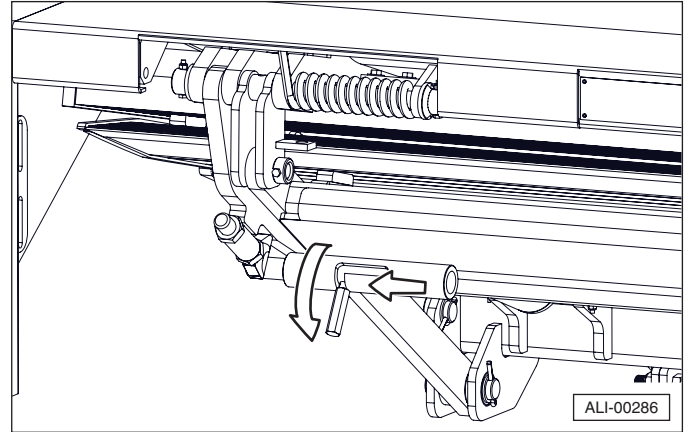

SAFETY INSTRUCTIONS



Many liftgate models provide drivers' steps as a convenience feature.

When steps are present, customer-supplied grab handles and other ingress/egress items should be installed.

4.3.11 Final Inspection Checklist

SAFETY INSTRUCTIONS

The installation procedure is not complete until all of the following items are checked and verified. If you have any questions, contact Anthony Liftgates.

- ❑ Operate the liftgate through its entire operational cycle (Up, Down, Fold In, Fold Out) several times. Make sure the liftgate operates evenly, freely, and smoothly, without unusual noise or vibration.

**ANTHONY TUCKUNDER LIFTGATES
OPERATING INSTRUCTIONS**

1. Raise (twist) latch pin handle upwards and then slide pin sideways to release.
Do not force the latch. Liftgate may need to be slightly raised or lowered to release pressure on latch pin.

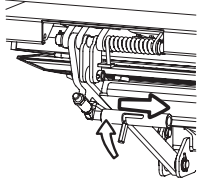

2. Press control switch DOWN until folded platform rests on ground.
Always stand on curbside of truck when raising or lowering platform with control switch.

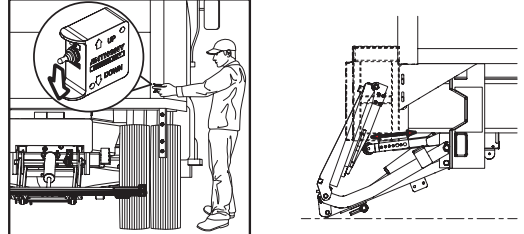

3. Manually unfold main platform.
Always stand on curbside of truck when unfolding platform.

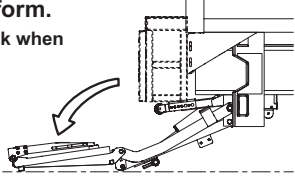

4. Manually unfold flipover section.
Always stand on curbside of truck when unfolding flipover section.

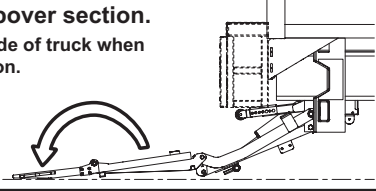

5. Raise and lower platform using UP and DOWN functions of control switch.

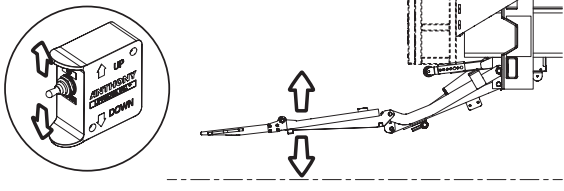

6. Reverse steps to fold and store platform. Make sure platform is locked in storage position with latch pin after use.

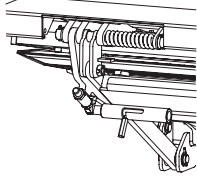

ATU-423

- ❑ Make sure the platform will fold smoothly and freely, tuck under the truck in a stored position, and latch.
- ❑ Make sure the latch pin works correctly.
- ❑ Make sure retainers are properly held in place on all factory-installed pivot pins.
- ❑ Make sure all hydraulic fittings are tight and not leaking.
- ❑ Hydraulic hoses must be routed to prevent rubbing against any surface while cycling the platform up/down or being opened/closed.
- ❑ Make sure the power unit reservoir is filled with Hyken Glacial Blue.

Gravity-down models - With the platform on the ground, the oil level should be within 1/2 inch of the top of the reservoir.

Power-down models - With the platform fully raised, the oil level should be within 1/2 inch of the top of the reservoir.

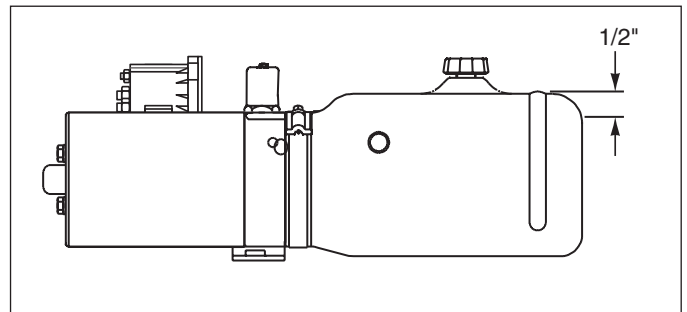

- ❑ Make sure the cover on the pump box is properly installed. It can also be secured with a customer-supplied padlock or lock pin.
- ❑ Make sure all welds are properly sized.
- ❑ Make sure reflectors, license plate bracket, and DOT lights are installed and operating properly, per FMVS 108 – Lamps, Reflective Devices, and Associated Equipment.
- ❑ If required, make sure a rear impact protection device is installed, according to FMVSS 223 – Rear Impact Guards and/or FMVSS 224 – Rear Impact Protection.
- ❑ Make sure truck brakes work properly, according to FMVSS 105 – Hydraulic And Electric Brake Systems.
- ❑ If required, make sure grab handles and other ingress/egress items are properly installed.
- ❑ If installed, make sure the optional cab cut-off switch or power cut-off solenoid work properly.
- ❑ Make sure all decals are properly attached and legible.
- ❑ Put the Installation, Operation, and Maintenance Manual in the vehicle.

4.4 Cut-Off Solenoid Connection

The installation of a cut-off solenoid is a recommended option for all 12 Volt electric liftgates. Installing a cut-off solenoid will help to prevent accidental or unauthorized use of the liftgate.

The optional A-133036 Cut-Off Solenoid Kit can be used in any truck, but is essential for tilt cab applications, as it requires only a lightweight wire running to the cab, not a large cable, as required by the cut-off switch.

Follow the directions on the installation instruction sheet that comes with the kit.

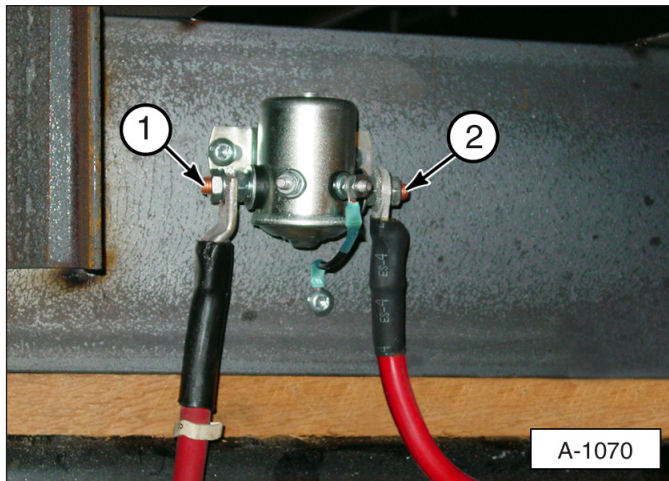

Cut-Off Solenoid Installed Between Battery and Fuse Assembly. (2) Short cable, part of solenoid kit. (1) Long length of power cable leading to power unit.

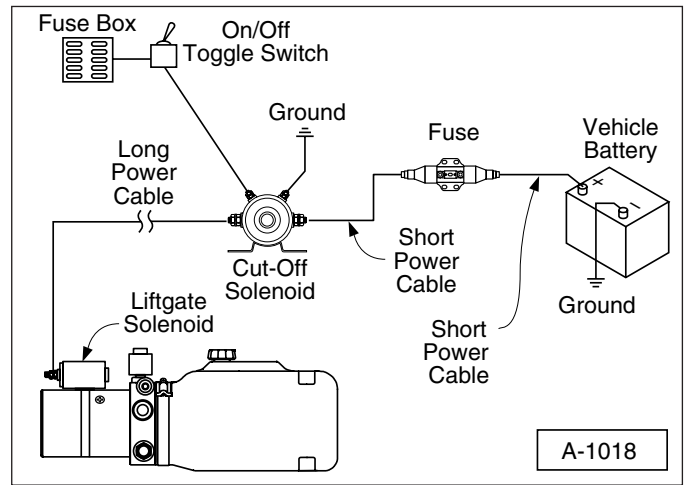

Wiring Diagram with Cut-Off Solenoid.

4.5 Cut-Off Switch Connection

The installation of a cut-off switch is also a recommended option for all 12 Volt electric liftgates. Installing a cut-off switch will help to prevent accidental or unauthorized use of the liftgate.

Follow the installation directions on the installation instruction sheet that comes with the kit.



Cut-Off Switch Mounted in Cab of Truck.

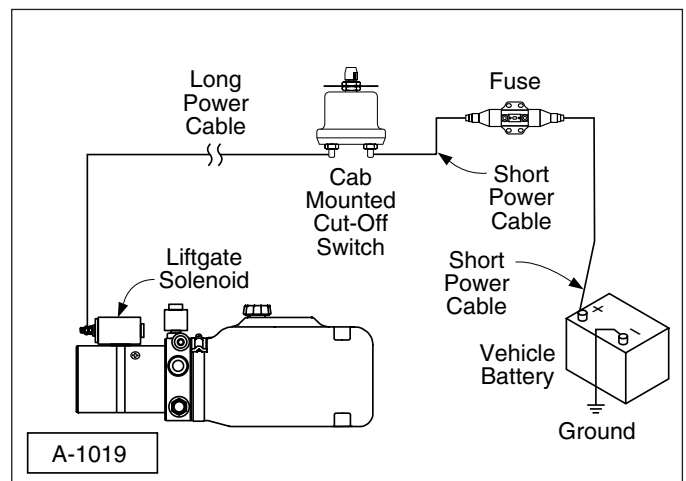

Wiring Diagram with Cab Cut-Off Switch.

4.6 Bolt-On Floor Extension

Use the following procedure to bolt the floor extension to the truck body.

1. Using a lifting device, align the holes in the floor extension with the predrilled holes in the truck body sill. A dimensional drawing showing the hole location can be found in this section.

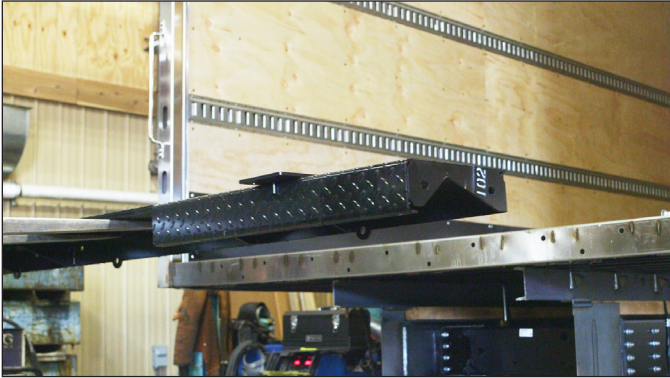

2. If the predrilled holes are not in the truck body sill, follow these steps.
 - a. Find and mark the center of the truck body.

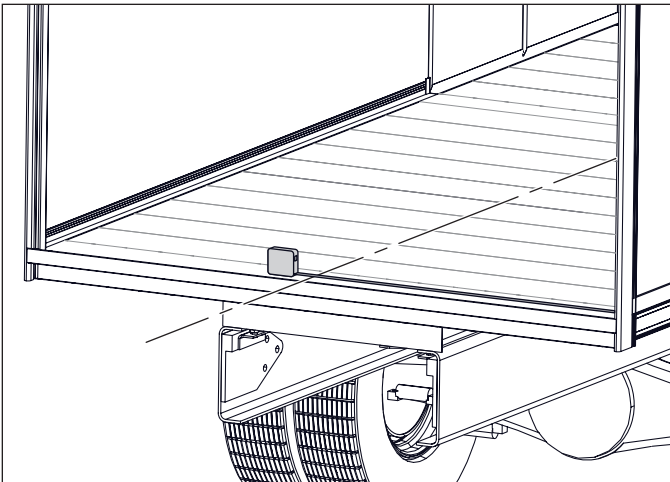

- b. Center the floor extension on the truck body using the notched cutout.

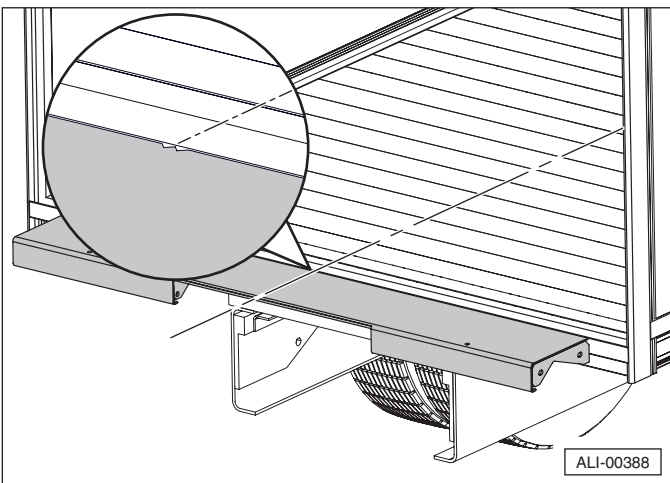

- c. Mark and drill mating holes.

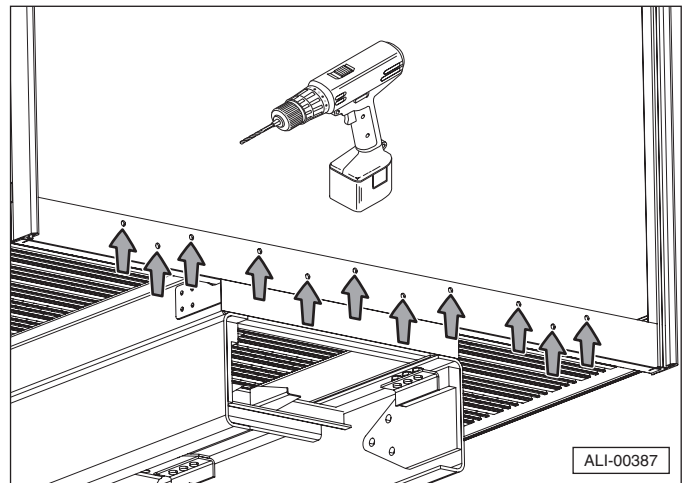
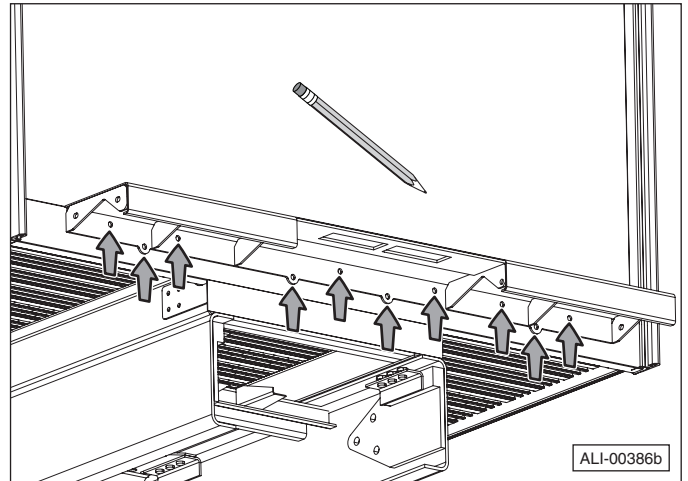

3. Install the flanged bolts through the floor extension and truck frame, with the bolt heads facing the rear of the truck.

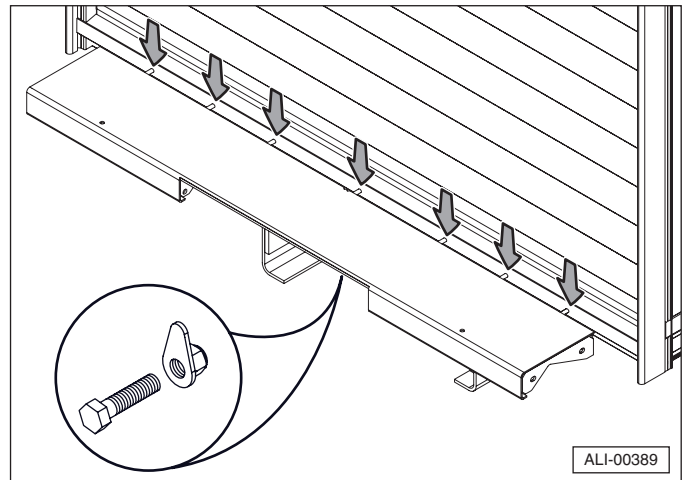

4. The floor extension has a natural bow in it and must be straightened as it is installed. Tighten the nuts from the center out, keeping the extension flush with the bed of the truck.

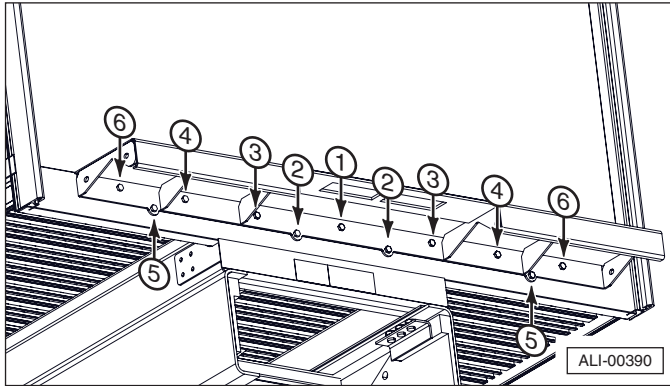

6. Bolt the side gussets onto each of the dock bumpers.

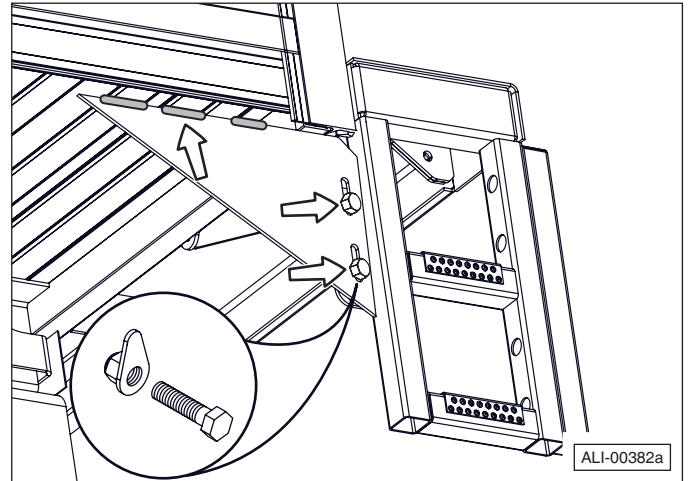

5. Install both dock bumpers.

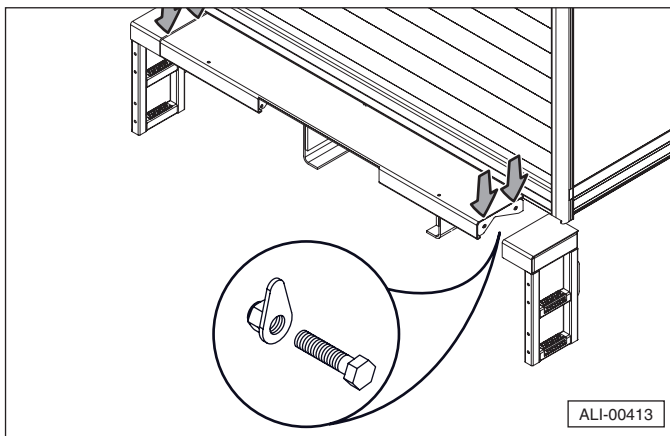

7. Weld the top of the side gussets to the truck body frame.

8. Make sure all bolts are tightened to standard torque.

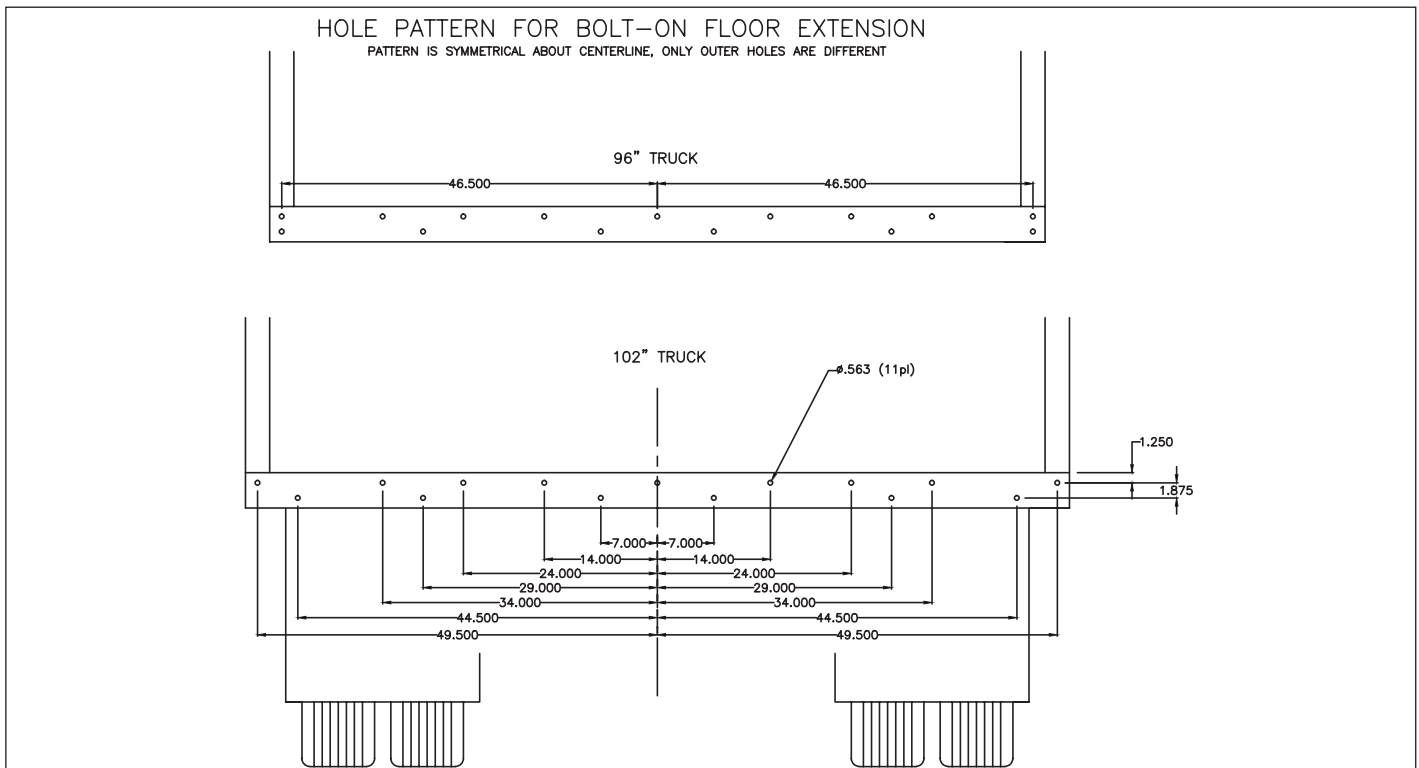

Bolt-On Floor Extension Hole Pattern.

5. Lifting Device

When installing several liftgates a year, the following lifting device can save time and make the installation process more efficient.

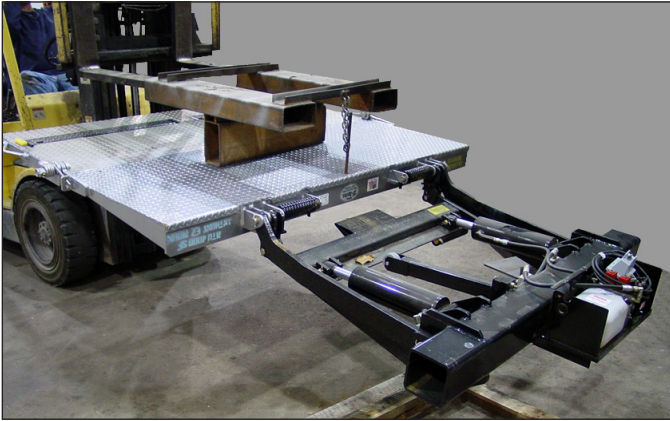

- This lifting device is intended for use on liftgates equipped with steel platforms. It is not compatible with aluminum platforms.
- Make the lifting device from tubular steel at least 1/4 inch thick or thicker.
- Make the lifting device wide enough to support the liftgate and to accommodate the width of the forks on the forklift.
- Make the lifting bolt from 5/8 inch threaded rod. Use a washer and nut to fasten the lifting device to the liftgate.
- The lifting bolt should be long enough to go through the lifting hole in the liftgate and allow the lifting device to remain level.

This lifting device must be made specifically for the type and design of the particular forklift used in the installation. Remember, the materials used to construct the lifting device must be capable of lifting and supporting the liftgate being installed. The lifting device must also contain a retaining method to hold it onto the forklift.

WARNING  The construction of the lifting device must satisfy the user to be safe and properly constructed. Failure to use the proper materials or material thickness can result in serious injury or death.

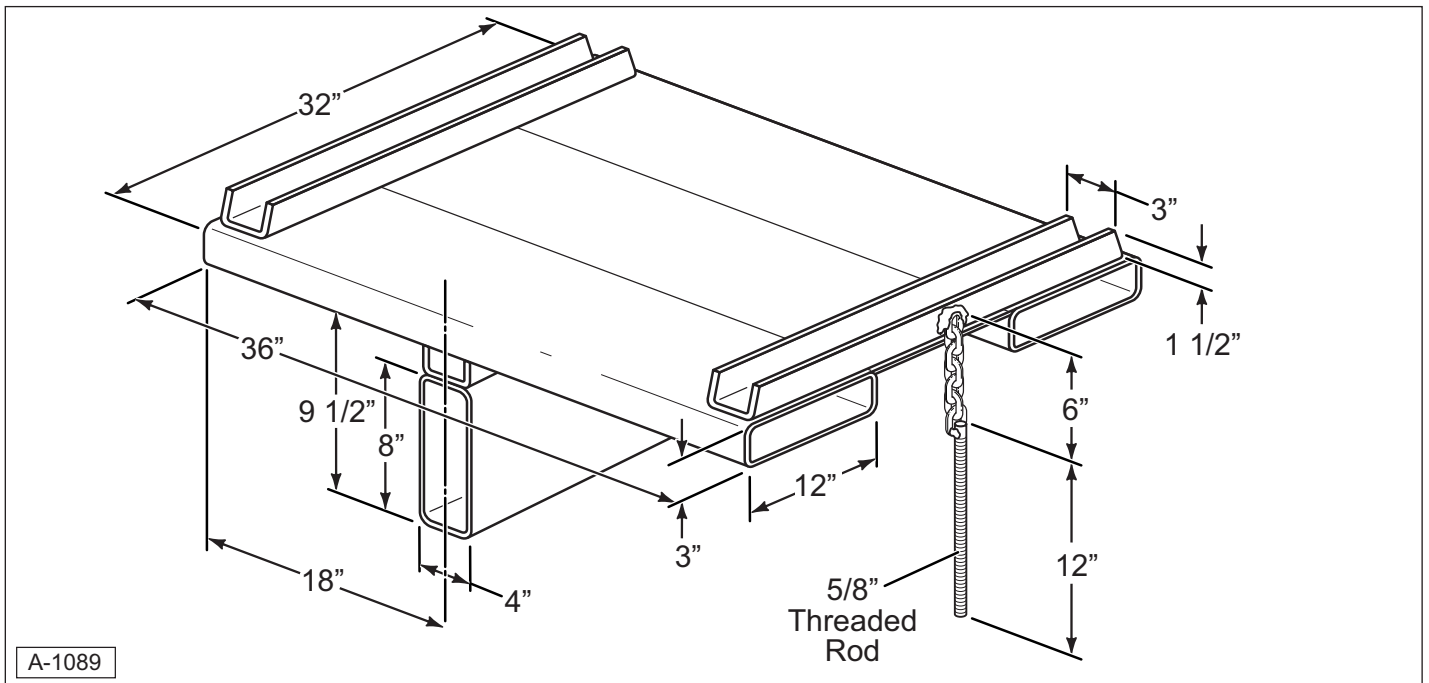

6. Trailer Sub Frame Installation

When mounting the liftgate to a trailer, it may be necessary to add a sub frame to provide attachment points. A DCT sub frame mounting kit is available from Anthony Liftgates for this purpose.

1. Locate the attachment points. Typical mounting widths for 96" and 102" wide trailers are shown below. In addition, the rear end of the sub frame must be 0" to 12" forward of the rear of the trailer body, and both ends of the sub frame must be on crossmembers.

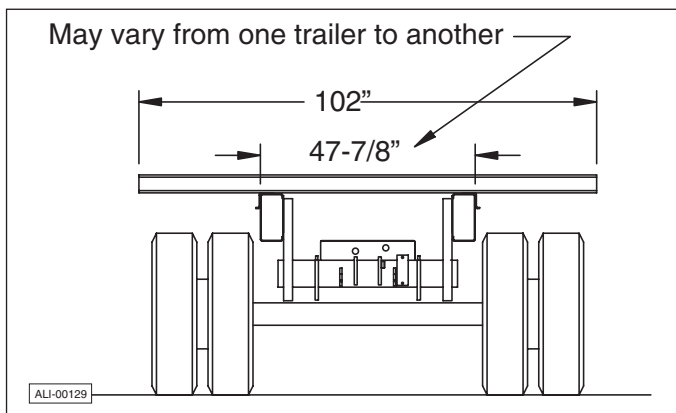
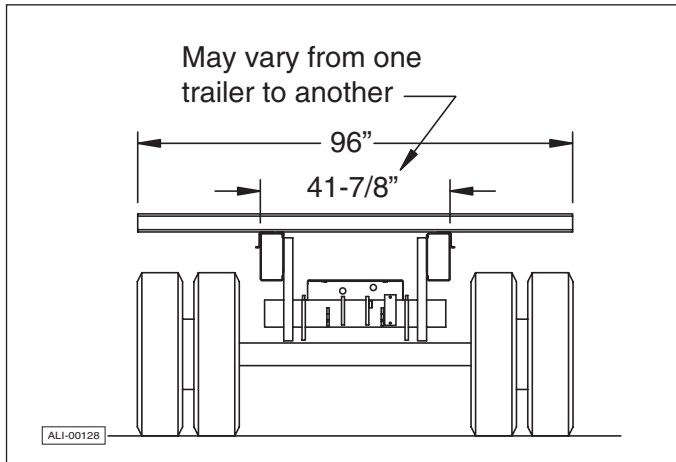

2. The end of the sub frame must be 0" to 12" forward of the rear of the trailer body, and must be on a crossmember.

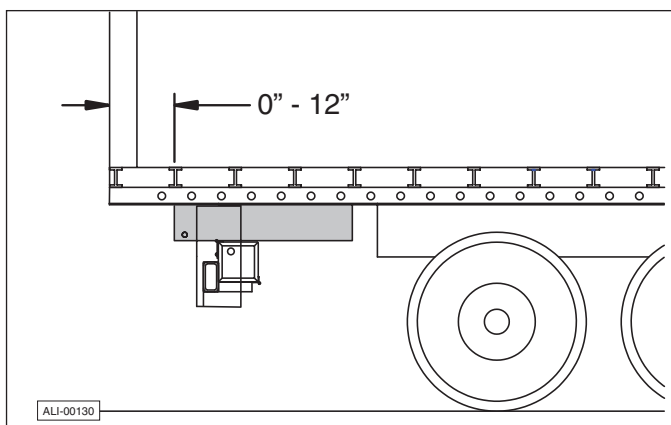

3. Weld the sub frame to the trailer crossmembers as shown. Both ends of the sub frame must be on crossmembers.

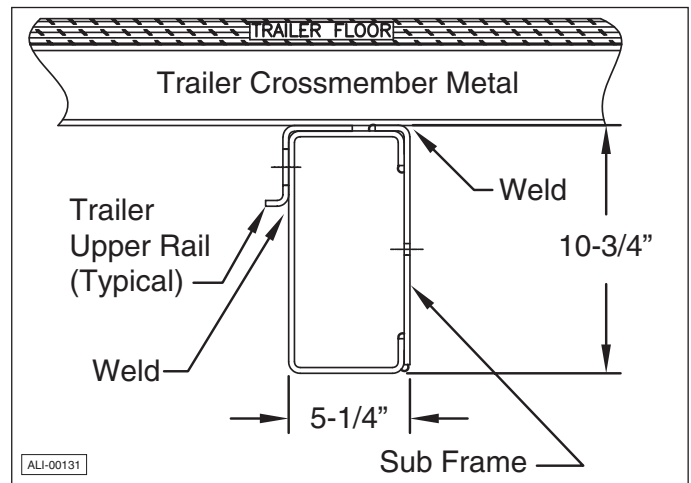

4. Mount the liftgate to the sub frame following the procedure in "4. Installation Section" on page 11.
5. If necessary, notch the sub frame as shown for proper folding clearance.

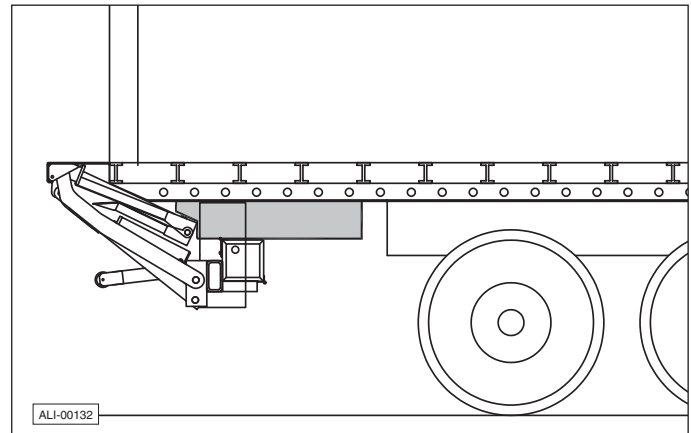

7. Decals

7.1 Decal Locations

SAFETY INSTRUCTIONS



To prevent possible injuries due to improper operation, make sure all decals are attached to the liftgate and/or truck and are legible at all times.

7.2 Replacement Parts and Hazard Decals

Dealers: To order replacement parts or hazard/informational decals, contact us through your normal dealer channels.

End Users: For ordering replacement decals, contact an authorized dealer by going to www.anthonyliftgates.com and selecting the FIND A DEALER tab. Enter your zip code to find the nearest authorized service location.

SAFETY INSTRUCTIONS



To prevent the personal injury of the end user from not being aware of safety recommendations, the installer must make sure all decals are attached to the liftgate and truck, and are legible.

Item	Part Number	Description
1	A-131115	Warning, Personal Injury
2	ATU-423	Operating Instructions
3	A-150238	Notice - Protected With Electrical Overload Circuit Breaker
4	ATU-141	After Using Liftgate
5	A-131061 A-131136	2500 Lb. Maximum Capacity 3300 Lb. Maximum Capacity
6	A-131034	Anthony Label
7	A-131017	Note - Disengage Latch
8	A-131028	Warning, 200 Amp Fuse Changing Procedure (attached to power cable)
9	A-131001	10 Amp Fuse Changing Procedure (attached to control wiring in pump box)
10	A-150601	Made In The USA
11	A-131133	Hydraulic Fluid
12	A-131028	Weld Warning
13	A-131125	Warning, Galvanized Fumes Hazard (only on galvanized models)

7.2.1 Customer Installed Decals

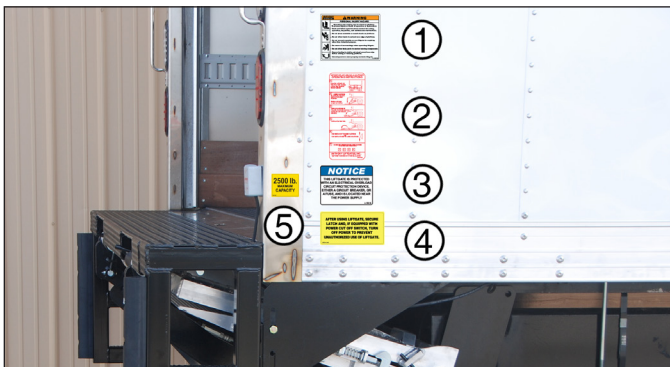

7.2.2 Factory Installed Decals

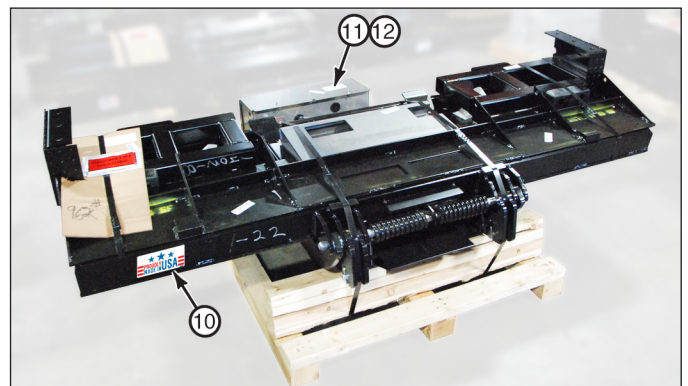
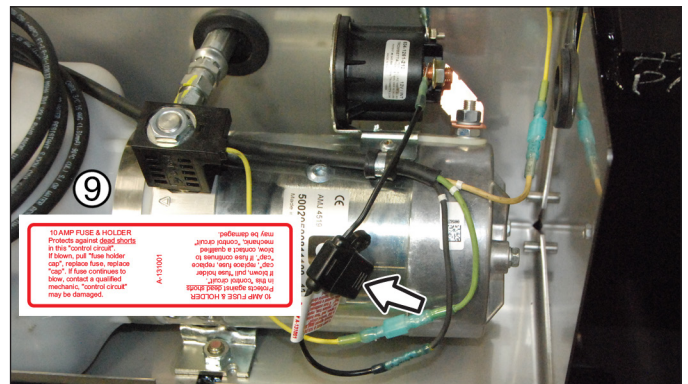
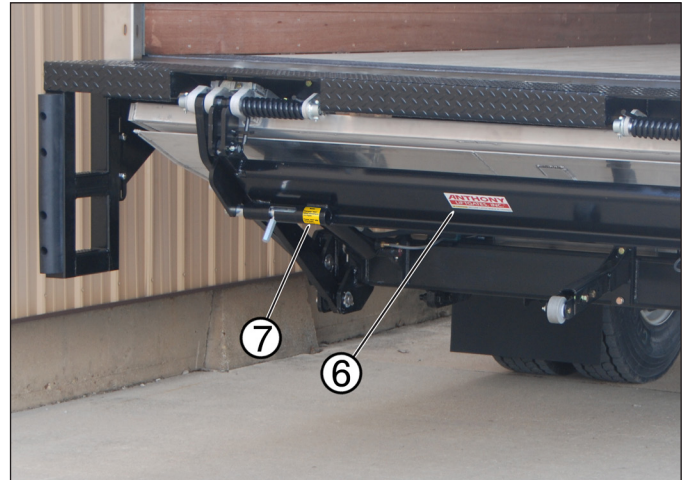

7.3 Decal Illustrations

1 — A-131115

ANTHONY LIFTGATES, INC.	
WARNING	
PERSONAL INJURY HAZARD	
	<p>Operation may require user to stand on platform. To prevent injury or death of operators or bystanders:</p> <ul style="list-style-type: none"> • Read and follow operator/owner manual for safety, operation, inspection, and maintenance instructions. • Do not place unstable or unsafe loads on platform. • Do not allow loads to extend over edge of platform. • Do not exceed capacity or use liftgate for anything other than intended purpose. • Be aware of surroundings when operating liftgate. • Do not allow body parts to contact moving components. • Ensure footing is stable and stand away from edge before raising or lowering platform. • Owner/operators must properly maintain liftgate.
<small>A-131115</small>	

2 — ATU-423

ANTHONY TUCKUNDER LIFTGATES
OPERATING INSTRUCTIONS

1. Raise (twist) latch pin handle upwards and then slide pin sideways to release.

Do not force the latch. Liftgate may need to be slightly raised or lowered to release pressure on latch pin.
2. Press control switch DOWN until folded platform rests on ground.

Always stand on curbside of truck when raising or lowering platform with control switch.
3. Manually unfold main platform.

Always stand on curbside of truck when unfolding platform.
4. Manually unfold flipover section.

Always stand on curbside of truck when unfolding flipover section.
5. Raise and lower platform using UP and DOWN functions of control switch.
6. Reverse steps to fold and store platform. Make sure platform is locked in storage position with latch pin after use.

ATU-423

3 — A-150238

NOTICE

THIS LIFTGATE IS PROTECTED WITH AN ELECTRICAL OVERLOAD CIRCUIT PROTECTION DEVICE, EITHER A CIRCUIT BREAKER, OR A FUSE, AND IS LOCATED NEAR THE POWER SUPPLY

A-150238

4 — ATU-141

AFTER USING LIFTGATE, SECURE LATCH AND, IF EQUIPPED WITH POWER CUT OFF SWITCH, TURN OFF POWER TO PREVENT UNAUTHORIZED USE OF LIFTGATE.

ATU-141

5 — A-131061 or A-131136

CAUTION

Make sure the proper “maximum capacity” decal is placed on the appropriate liftgate. For example, the A-131061 “2500 lb. Maximum Capacity” decal goes on DCT-2500 models only. Do not put a higher rated decal (3300 pound) on a liftgate with a lower capacity; this could result in liftgate damage or possibly personal injury.

2500 lb.

MAXIMUM CAPACITY

A-131061

3300 lb.

MAXIMUM CAPACITY

A-131136

6 — A-131036 (attached to liffframe)



10 — A-150601 (attached to platform)



7 — A-131017 (attached near latch mechanism)



11 — A-131133 (attached to pump box)

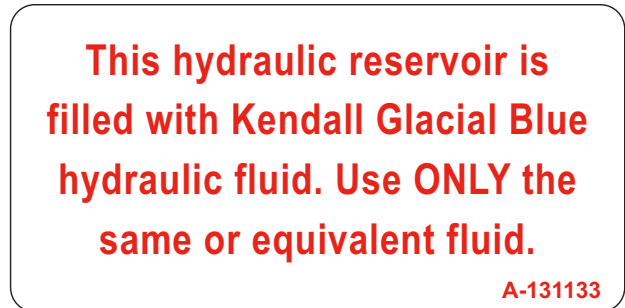

12 — A-131028 (attached to pump box)

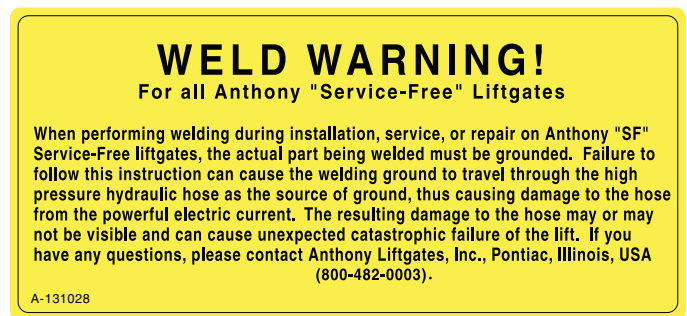

8 — A-131036 (on the power cable)

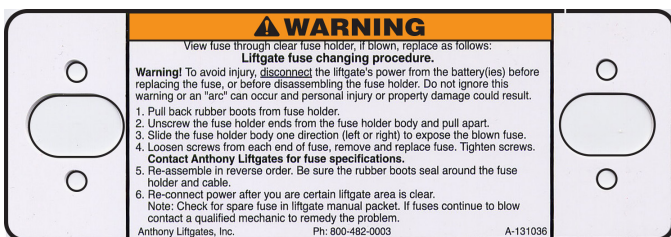

13 — A-131125 (attached to adapter tube frame of galvanized liftgates)

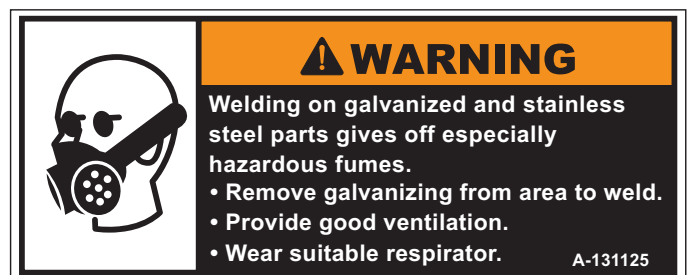

9 — A-131001 (inside the pump box)

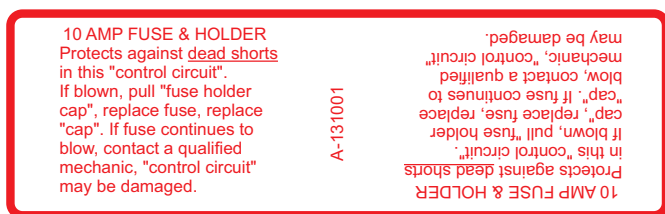

8. Operation Section

8.1 General Operating Safety Instructions



WARNING  Do not use this liftgate for any other purpose than its intended use of loading and unloading cargo from the bed of a truck.

 Do not overload the platform. The maximum rated capacity is based on an evenly distributed load on the platform's flat surface.

 – Do not stand in the platform's work area while operating the liftgate. Serious injury or death could result if the load shifts, falls, or is unstable on the platform.

– Do not go under the liftgate while it is in a raised position. Accidental lowering could cause serious crushing injuries.



– Do not stand under or place any object under the liftgate work area.

  To prevent personal injury, immediately clean up any spilled fluid on the liftgate platform. To avoid tripping, do not leave anything laying on the platform or around the work area.

 Do not allow children to play on/around or operate the liftgate.

CAUTION   Always use/set the truck's parking brake and remove the ignition key before operating the liftgate. Failure to follow this recommendation can result in injury.

    Do not place hands or feet in pinch points, between the platform and the platform extension, or under the edge of the liftgate.

  Anthony Liftgates recommends not riding the liftgate; however, if the operation requires it, make sure your footing is stable before raising or lowering the platform. Always stand away from the edge. When on the ground, always stand clear of the liftgate when it is operating.

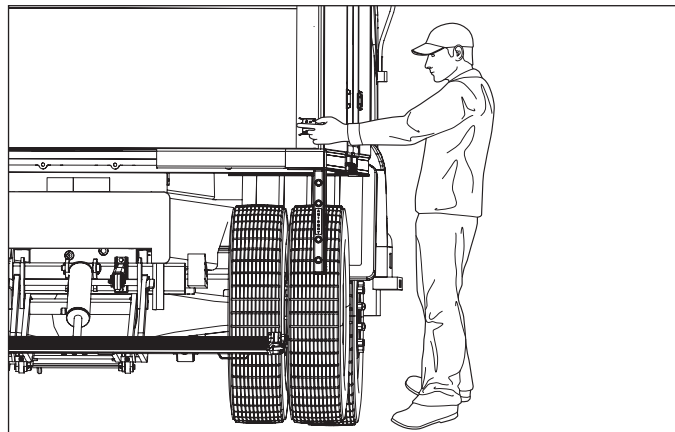



SAFETY INSTRUCTIONS

 Do not allow the liftgate to be used by persons unfamiliar with its operation.

 Visually inspect the liftgate before use to make sure all parts are in good working condition and operates freely. Have any damaged parts replaced immediately.

 To prevent possible injuries due to improper operation, make sure all decals are attached to the liftgate and/or truck and are legible at all times.

 Always use three points of contact during ingress or egress of the truck or platform.

 Make sure the area in which the platform will open and close is clear before opening, closing, raising, or lowering the platform.

 Always place the load as close to the center of the platform as possible and as close to the truck as possible.

 Only operate the liftgate with the switch controls mounted on the truck body unless an optional hand-held remote is installed.

 Do not operate lift trucks on or over any part of the platform.

 Do not use the liftgate if it shows signs of abuse or fails to operate freely.

NOTICE

Do not allow the motor/pump to run after the liftgate is closed, or fully raised.

Do not bounce the platform by pushing and releasing the control switch abruptly.

8.2 Operating Instructions

**ANTHONY TUCKUNDER LIFTGATES
OPERATING INSTRUCTIONS**

- 1. Raise (twist) latch pin handle upwards and then slide pin sideways to release.**
Do not force the latch. Liftgate may need to be slightly raised or lowered to release pressure on latch pin.

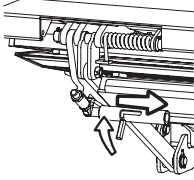

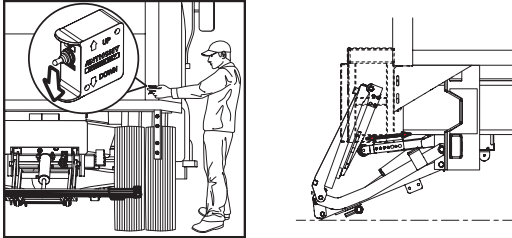
- 2. Press control switch DOWN until folded platform rests on ground.**
Always stand on curbside of truck when raising or lowering platform with control switch.

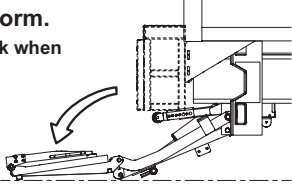
- 3. Manually unfold main platform.**
Always stand on curbside of truck when unfolding platform.

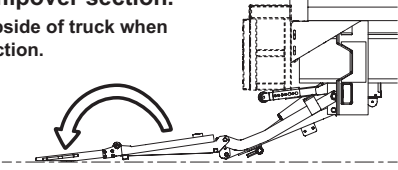
- 4. Manually unfold flipover section.**
Always stand on curbside of truck when unfolding flipover section.

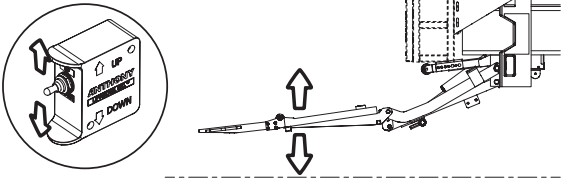
- 5. Raise and lower platform using UP and DOWN functions of control switch.**

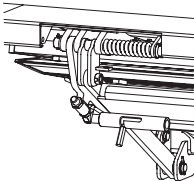
- 6. Reverse steps to fold and store platform. Make sure platform is locked in storage position with latch pin after use.**



ATU-423

1. Raise and slide the latch pin toward the curbside of the liftgate.



NOTICE Do not force the pin to open. In some cases, the liftgate can settle down against the pin, causing it to bind or be very difficult to slide. If the pin does not slide easily, slightly raise the liftgate to relieve pressure on the latch pin.

2. Press and hold the control switch in the DOWN position until the folded platform rests on ground.

CAUTION Always stand on curbside of truck when raising or lowering platform with control switch.

3. Manually unfold the platform.



CAUTION Always stand on curbside of truck when unfolding platform.

- Release the flipover section latch pin and manually unfold the flipover section.

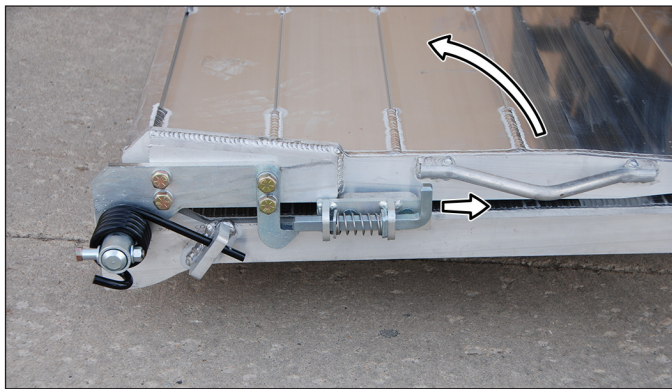

Always stand on curbside of truck when unfolding flipover section.

- Raise and lower the platform using the UP and DOWN functions of the control switch.



Do not bounce the platform by pushing and releasing the control switch abruptly.



Do not allow the motor/pump to run after the liftgate is closed, or in the up position.

- Reverse steps to fold and store platform. Make sure the platform is locked in storage position with the latch pin.



When placing the liftgate in the storage position (folding), slowly fold the platform until it contacts the wheel arm assembly. Lock the liftgate into the storage position with the latch pin whenever the liftgate is not in use.



The latch pin is only for in-transit locking of the liftgate. DO NOT slide the latch pin into the latched position when the platform is unfolded and raised. If this occurs, serious damage to the liftgate can occur when the liftgate is lowered.

9. Maintenance Section

WARNING



To prevent serious bodily injury,

keep sparks, lighted matches, and open flames away from the top of the battery, because battery gas can explode. Always follow all the manufacturers' safety recommendations when working around the truck's battery.



To prevent personal injury, clean up any spilled fluids immediately. To avoid tripping, do not leave tools or components laying around in the work area.

9.1 Monthly Inspection

All Anthony Tuckunder Liftgates are "Grease-Free", which means they have lubrication-free bushings at the major pivot points.

1. Make sure the liftgate operates freely and smoothly throughout its entire range of movement.
2. Check for damage to the liftgate, such as bent or distorted parts. Check for excessively worn parts.
3. Check for cracked welds which may have resulted from overload or abuse.
4. Check all pins and pivot points. Make sure they are secured with proper retainers. Replace worn bushings and/or pins.
5. Make sure the platform is angled upward from the truck bed 1 to 1-1/2 inch when raised to bed height. See "9.3.1 Platform Adjustment (adding shims)" on page 39 for shimming procedure.
6. Make sure all electrical wires, switches, and connections are in good working condition and operate properly.
7. Check for oil leaks in the following areas:
 - a. Hydraulic lift cylinder.
 - b. Hydraulic hoses. Replace any hose that shows signs of leakage or excessive abrasion of the covering.
 - c. Check all hydraulic fittings for damage or leakage. Tighten fittings to stop leaks or replace if damaged.
8. Check reservoir oil level and fill as required with Hyken Glacial Blue.
 - a. Gravity-down models - With the platform on the ground, the oil level should be within 1/2 inch of the top of the reservoir.
 - b. Power-down models - With the platform in the fully raised position, the oil level should be within 1/2 inch of the top of the reservoir.

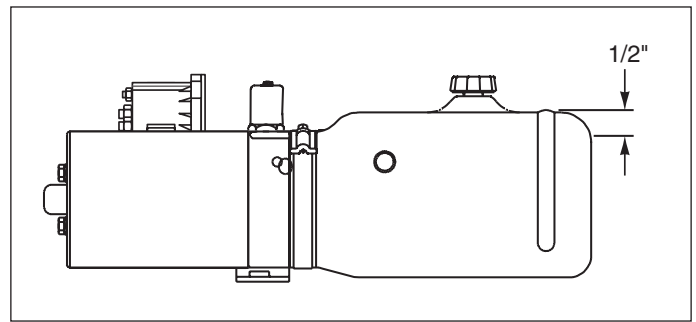

NOTICE

Use only Hyken Glacial Blue hydraulic fluid in the power unit reservoir. If an emergency situation occurs, any anti-wear hydraulic fluid can be used, but the system should be flushed and the fluid changed as soon as reasonably possible. Hydraulic fluids should not be mixed due to possible compatibility problems.

DO NOT thin hydraulic fluid with brake fluid, and *DO NOT* use brake fluid in place of hydraulic fluid.

9. Check the fluid level of the vehicle battery. Fill as required.
10. Examine all warning, capacity, and operational decals. If they are not readable, they should be replaced. Decals may be obtained free of charge from Anthony Liftgates, Inc.
11. Oil the roller of the wheel arm and make sure it spins freely.

9.2 Semi-Annual Inspection

In addition to the items requiring monthly inspection, also inspect the condition of the hydraulic fluid.

If the oil in the hydraulic tank is dirty, drain the oil and flush the entire system. Refill the system with the recommended oil.

9.3 Maintenance and Troubleshooting Procedures

9.3.1 Platform Adjustment (adding shims)

The ramp (outboard) end of the platform should be 1 to 1-1/2 inches higher than the truck floor when in the raised position. If the outboard end of the platform is sagging, add shims as described below. Shimming is a normal procedure as the liftgate ages and the parts become worn.

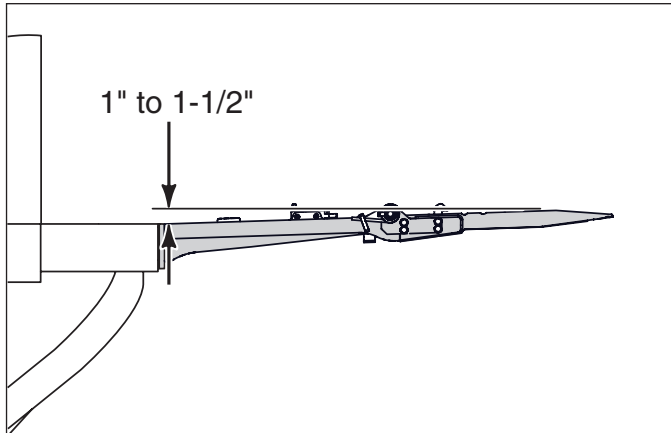

1. Position the necessary amount of "shim plates" in the contact area between the cam plates and platform.

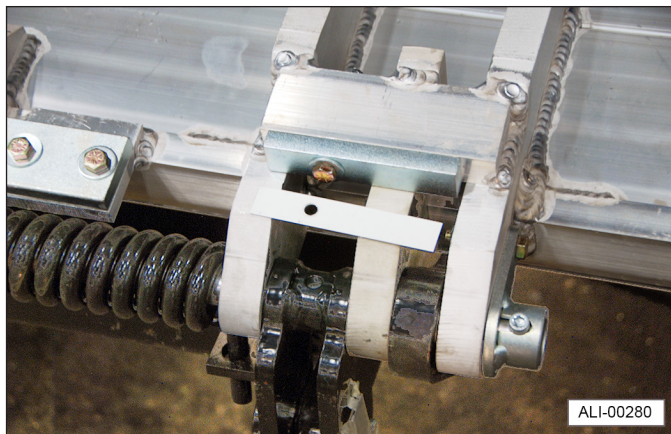

Add shims to this area to eliminate sagging.

2. Bolt the shim plates to the blocks on the platform.
3. When the platform is lowered to the ground, it should touch at the lift arm end and at the ramp end.

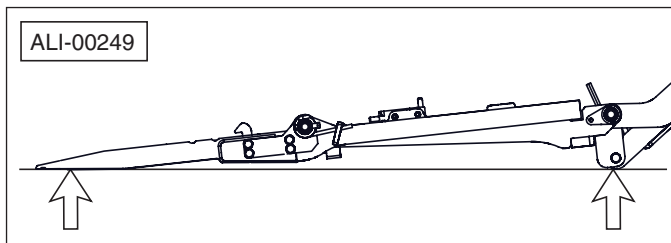

Liftgate should contact the ground at these two locations.

9.3.2 Replacing the Fuse



An electric arc can cause personal injury or property damage. To avoid personal injury, disconnect the power cable from the vehicle battery or batteries before replacing the fuse, or before disassembling the fuse holder.

1. Slide the rubber boots away from the fuse holder.

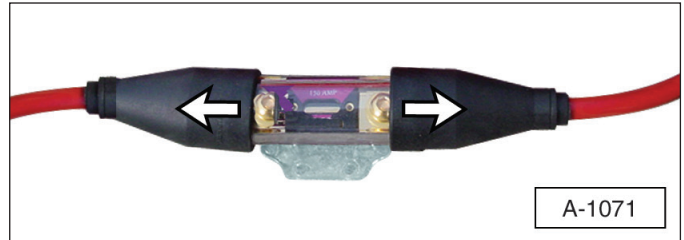

2. Unscrew the fuse holder ends from the fuse holder body and pull it apart.

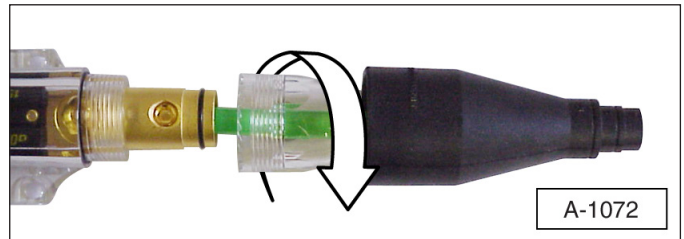

3. Slide the fuse holder body one direction (left or right) to expose the damaged fuse.
4. Loosen the screws from each end of the fuse, remove, and replace the fuse. Retighten the screws.
5. Re-assemble the fuse holder in reverse order. Be sure the rubber boots are sealed around the fuse holder and power cable.
6. Re-connect the power after you are certain the liftgate area is clear.

9.3.3 Checking Motor Start Solenoid and Power Cut-off Solenoid

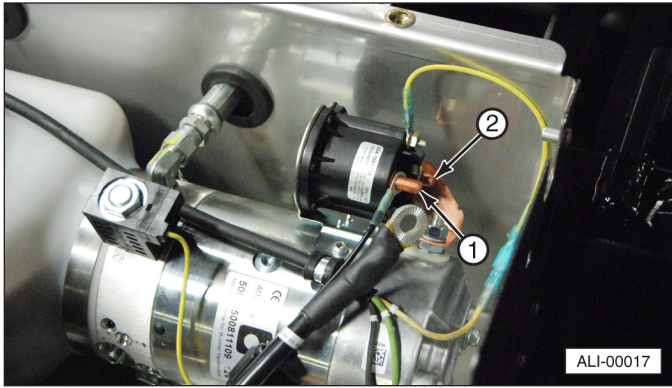

Motor start solenoid.

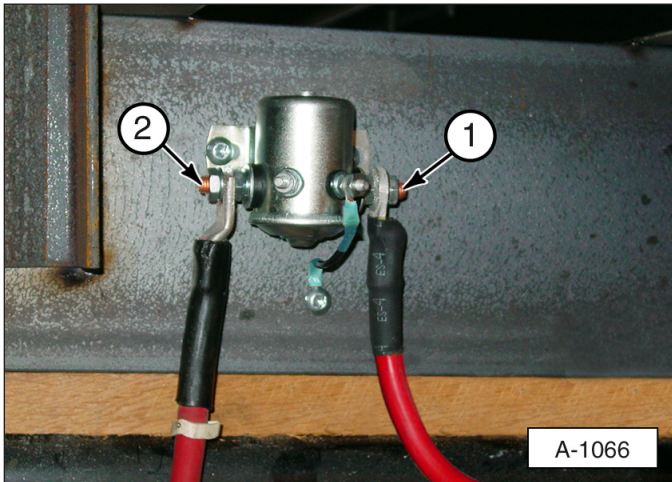

Power cut-off solenoid.

Both the motor start solenoid and power cut-off solenoid can be checked by bypassing the solenoid itself.

1. Use jumper cables for this test.
2. Connect one jumper cable to battery side (2) of the solenoid. Connect the other cable to motor side (1) of the solenoid.
3. If the liftgate is activated, the solenoid is defective and should be replaced.

9.3.4 Checking the Power Cable

To check for a defective power cable, run the motor directly from a spare battery using jumper cables.

1. Remove the battery connection to the motor.
2. Connect the negative jumper cable (ground) directly to the liftgate. Connect the positive cable to the terminal on the motor start solenoid.
3. If the motor operates, the battery cable is defective and should be replaced.

9.3.5 Checking Lowering Valve Cartridge and Solenoid

1. Place the liftgate on the ground in the open position.
2. Place a steel screwdriver over the top of the lowering valve solenoid.

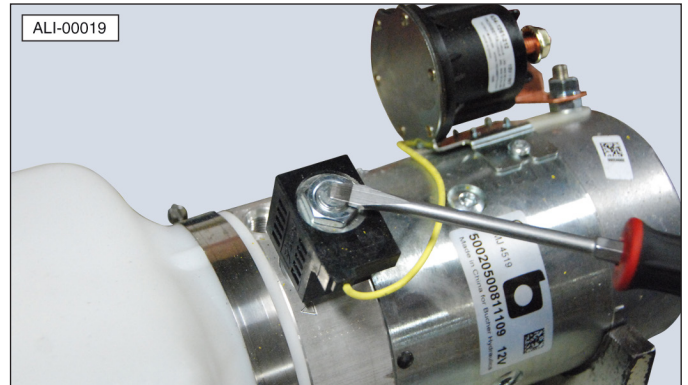

3. Momentarily activate the control switch in the DOWN position. The screwdriver should be attracted to the magnetic field created by the solenoid.
4. If no magnetic pull is produced, the solenoid is defective and should be replaced. If the solenoid is activated, check the cartridge valve.
5. Remove the solenoid from the valve assembly.
6. Remove the valve cartridge from the pump body.
7. Clean the cartridge and blow it dry with compressed air (not greater than 30 psi). Also, blow out the pump body.
8. Use a small screwdriver and carefully press on the spool inside the cartridge. If the spool moves freely, the cartridge is good. If it does not move, replace the cartridge, as the spool could be bent, pitted, or otherwise damaged.



9.3.6 Solenoid Valve Screen

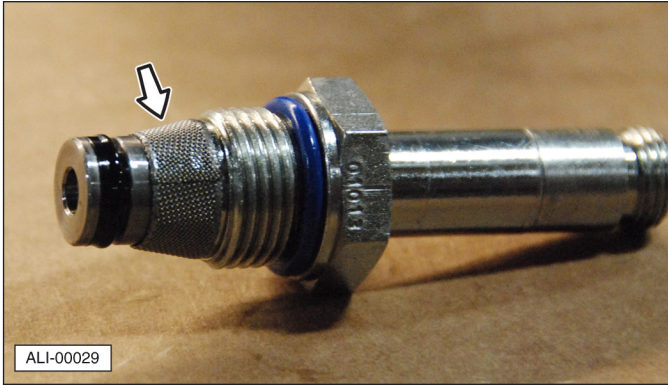

If the solenoid is working electrically, check the debris screen and clean if dirty.

9.3.7 Replacing Solenoid Valve

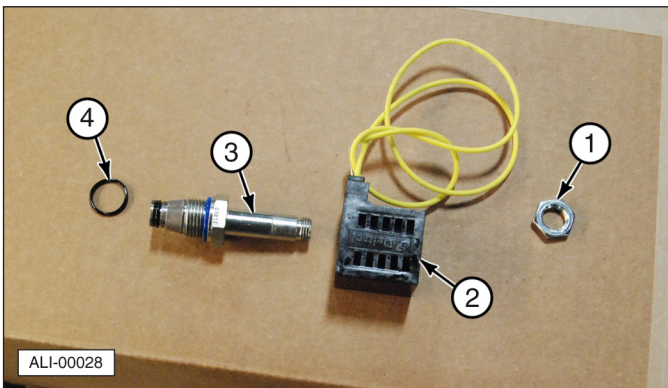
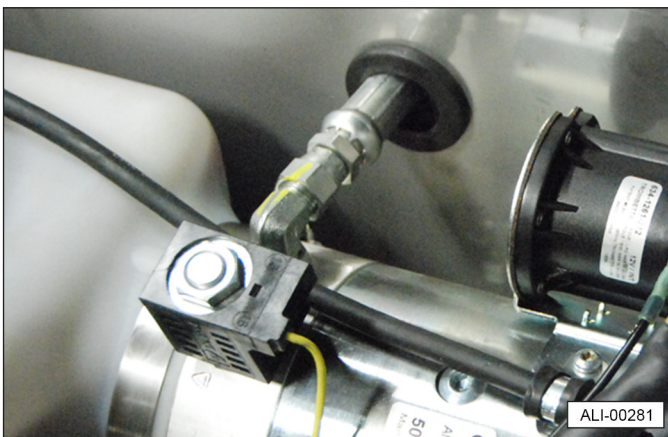

1. While installed in the pump, remove nut (1).
2. Remove coil (2) from cartridge (3).
3. Remove cartridge (3) from pump body.
4. O-ring (4) is not required on current models and can be discarded.

9.3.8 Checking System Pressure

For gravity-down systems, there is only one relief valve (power up). Power-down models have two relief valve settings; one for raising the platform (power up) and one for lowering the platform (power down).

To check the “power up” pressure setting:

1. Place the liftgate on the ground and remove the pressure hose from the power up port of the pump.
2. Install a T-fitting (customer supplied) into the power up port.
3. Connect a pressure gauge and reconnect the hydraulic hose.

The pressure gauge must be rated above the maximum pressure of the liftgate. For example, use a 4000 psi pressure gauge on a 3000 psi maximum capacity liftgate.

4. Raise the liftgate and check the pressure on the gauge.

Low Pressure Threshold Chart		
Model	Power Up	Power Down
DCT-2500	1000 psi	350 psi
DCT-3300	1300 psi	

WARNING Do not stand or work in the platform's work area while operating the liftgate. Place the pressure gauge so it can be read while operating the liftgate from a safe location. Serious injury or death could result if this action is not followed.

5. Check the power down relief valve pressure in the same way as the gravity down system by installing a T-fitting and pressure gauge.

9.3.9 Checking Cylinder Piston Seals (drifting - caused by seal leakage)

Gravity Down Models

1. Remove the breather hose (gravity down models only).
2. Completely raise the liftgate and hold the switch in the "UP" position while checking for oil flowing out of the cylinder's breather port.
3. If a continuous flow of oil comes out of this port (while the liftgate is all the way up and the switch is held "UP"), then the piston seals are leaking and the cylinder should be replaced.

Power-down Models

1. Check the lowering valve. Make sure it is operating correctly and the valve is not sticking or dirty. Refer to "9.3.5 Checking Lowering Valve Cartridge and Solenoid" on page 40.
2. If the lowering valve is operating properly, then the drifting is most likely caused by worn piston seals. Replace the cylinder.

9.3.10 Checking Flow Control Valve

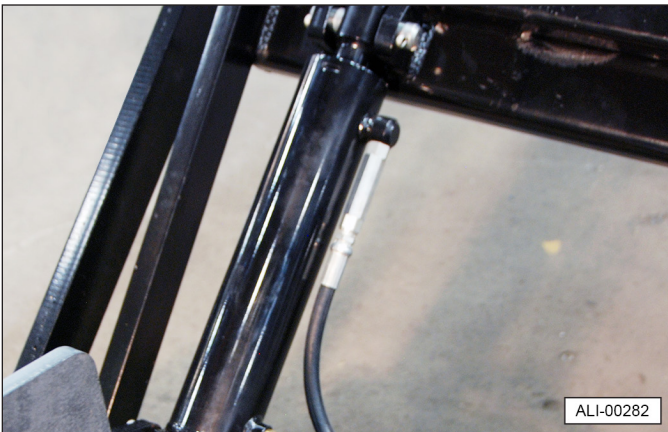

If the cylinder does not operate or operates slower than normal, remove the flow control valve and hook the hydraulic hose directly to the cylinder. If the cylinder operates properly, replace the flow control valve.



Do not operate the liftgate without the flow control valve. Serious injury or death could result if this action is not followed.

9.3.11 Checking Control Switch Fuse

If the control switch is not operating the liftgate, check the in-line fuse located on the control cable inside the power unit box.

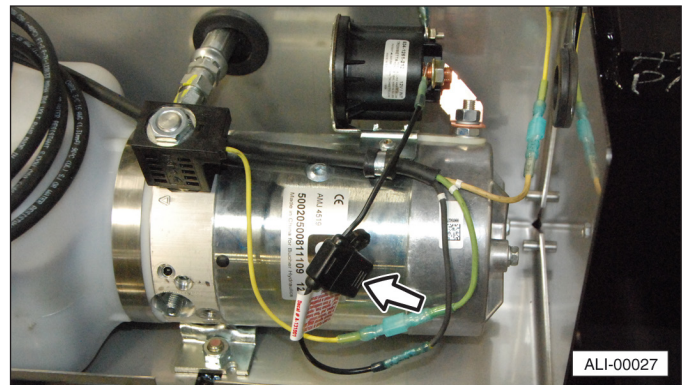
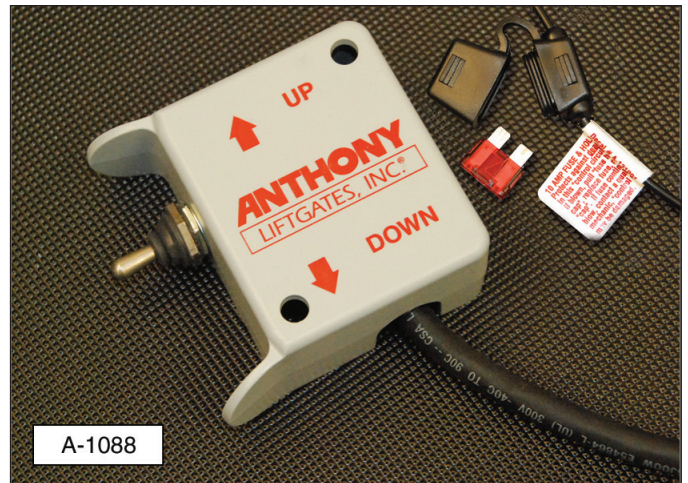

10. Troubleshooting

10.1 Troubleshooting Guide

Troubleshooting Chart		
Problem	Possible Causes	Possible Solution
Motor does not run when control switch is activated.	Cab cut-off switch.	Turn switch to ON position. "4.5 Cut-Off Switch Connection" on page 27.
	Dead battery.	Make sure battery is fully charged. Check for loose or corroded battery connections. Replace or recharge battery.
	Circuit protection (fuse or breaker).	Replace fuse.
	10 Amp fuse in power unit box.	Replace, if fuse is blown. If problem continues, check for shorts in the electrical system.
	Control box switch.	Check fuse. "9.3.2 Replacing the Fuse" on page 39.
	Motor start solenoid.	Check solenoid. "9.3.3 Checking Motor Start Solenoid and Power Cut-off Solenoid" on page 40.
	Optional power cut-off solenoid.	Check solenoid. "9.3.3 Checking Motor Start Solenoid and Power Cut-off Solenoid" on page 40.
	Battery cable.	Connect motor directly to a spare battery using the procedure in the Maintenance section.
	Motor.	If the motor is determined to be defective, it should be replaced. Defective motors are typically caused by weak batteries (low voltage), loose connections, corrosion, or a poor ground.
	If liftgate is installed on a semi trailer, make sure the battery wire is 2 Gauge or heavier. Smaller wires can reduce the voltage, resulting in motor failures.	
If the motor does not operate in freezing conditions, make sure the motor housing does not contain water.		
Sagging platform.	Normal wear.	Add shims to platform. "9.3.1 Platform Adjustment (adding shims)" on page 39.
	Bushing wear where lift arms connect to platform.	Replace bushings.
	Structural damage.	Replace worn parts.
Foaming oil.	Air in the hydraulic hose(s).	Check oil level in reservoir. "9.1 Monthly Inspection" on page 38.
	Broken or loose fluid return tube.	Remove the oil reservoir and make sure the return tube is below the oil level. If the tube has turned or fallen out, reinstall it into the pump housing. Use a center punch to "stake" the tube into position.

Troubleshooting Chart		
Problem	Possible Causes	Possible Solution
Motor runs, but liftgate will not open or lower to the ground.	Structural damage. Check clearance between platform and dock bumpers.	Fix damage. Replace worn parts.
	Latch pin.	Slide the latch pin to the open position.
	Lowering valve solenoid.	Check the solenoid. "9.3.5 Checking Lowering Valve Cartridge and Solenoid" on page 40.
	Lowering valve cartridge.	Check, remove, and clean valve cartridge using the procedure in the Maintenance section. "9.3.5 Checking Lowering Valve Cartridge and Solenoid" on page 40.
	Flow control valve.	Remove flow control valve and hook hydraulic hose directly to the cylinder. If the cylinder operates properly, replace the valve. "9.3.10 Checking Flow Control Valve" on page 42.
Motor runs, but platform will not raise, will not raise rated capacity, or raises, but drifts down when control switch is released.	Load capacity has been exceeded.	Verify load capacity and adjust load weight.
	Structural damage.	Replace damaged parts.
	Low fluid level.	Fill reservoir. "9.1 Monthly Inspection" on page 38.
	Low Voltage.	Inspect the battery connection terminals and check the battery's Voltage. If less than 12 Volts, recharge battery.
	Faulty lowering valve.	Solenoid or cartridge may need cleaning or replacement. See Maintenance section. "9.3.5 Checking Lowering Valve Cartridge and Solenoid" on page 40.
	Defective piston seals.	See Maintenance section for Checking Cylinder for Leakage. "9.3.9 Checking Cylinder Piston Seals (drifting - caused by seal leakage)" on page 42.
	Hydraulic pump is worn.	Replace hydraulic pump.
Latch pin is broken or bent.	Operator has lowered platform without releasing latch pin.	The latch pin is only used to prevent the liftgate from opening due to a pressure leak or pressure bleed-off over an extended period of time. Always release latch before opening liftgate.
Liftgate raises truck when lowered to the ground.	Power-down system pressure is set too high.	See Maintenance section for Checking System Pressure. "9.3.8 Checking System Pressure" on page 41.
Liftgate will not open.	Platform operating area is not clear.	Clear platform operating area.
	Latch pin will not slide freely to release liftgate.	Activate the "UP" switch and raise the liftgate to the fully stored position. The latch pin should slide freely.

Troubleshooting Chart		
Problem	Possible Causes	Possible Solution
Platform lowers extremely slow.	Low oil level on power-down models.	Fill reservoir. "9.1 Monthly Inspection" on page 38.
	Improper oil in hydraulic reservoir.	See Monthly Inspection. "9.1 Monthly Inspection" on page 38.
	Bushing wear where lift arms connect to platform.	Replace bushings.
	Damaged or kinked hydraulic hose.	Repair or replace.
	Cylinder rod is scored, pitted, or bent.	Replace cylinder.
	Flow control valve.	Remove flow control valve and hook hydraulic hose directly to the cylinder. If the cylinder operates properly, replace the valve. "9.3.10 Checking Flow Control Valve" on page 42.
	Lowering valve.	Solenoid or cartridge may need cleaning or replacement. See Maintenance section. "9.3.5 Checking Lowering Valve Cartridge and Solenoid" on page 40.
Platform raises partially and stops.	Load capacity has been exceeded.	Verify load capacity and adjust load weight.
	Structural damage.	Replace damaged parts.
	Low Voltage.	Recharge battery (if less than 12 Volts).
	Low pressure.	Refill reservoir. Check pump and motor. "9.3.8 Checking System Pressure" on page 41.
Platform will not lower.	Platform operating area is not clear.	Clear area.
	Structural damage.	Replace damaged parts.
	Low Voltage.	Recharge battery (if less than 12 Volts).
	Lowering valve.	See Maintenance section. "9.3.5 Checking Lowering Valve Cartridge and Solenoid" on page 40.
	Hydraulic pump and motor.	Replace power unit.

12. Limited Warranty

12.1 Limited Warranty

DCT - 2 yrs/6,000 cycles Mechanical/Electric/Hydraulic

Thank you for purchasing an Anthony liftgate. We strive to produce the most trouble-free and reliable liftgates in the market. We are sure you will experience years of reliable operation. To further ensure your confidence in Anthony, this warranty will cover your unit for 2 years or 6,000 cycles (whichever occurs first) on mechanical/structural, electrical, and hydraulic operating parts. This warranty is extended to the original purchaser (user only) and is not transferable. The warranty term begins from the date of shipment from our factory or warehouse.

Anthony Liftgates Inc. will cover all failed components during the warranty period. Labor will be provided under our Flat Rate Warranty Schedule, in effect at the time of the part failure, and includes diagnosis time. Contact Anthony for current reimbursement amounts. For repairs NOT listed on the Flat Rate Warranty Schedule, contact the Anthony Warranty Department for approved reimbursement, prior to performing repairs. Anthony Liftgates Inc. reserves the right of determination of whether a component is defective or has failed. This warranty applies to Anthony liftgates installed, operated, and maintained in accordance with Anthony Liftgates Inc. installation, operation, and maintenance manuals, videos, etc.

Certain Anthony models have published Lifetime Warranties on listed components, as published in current literature. This additional coverage will be detailed on the published operation components, providing the unit has been operated and maintained within the intended usage.

Anthony Liftgates, Inc. will process all claims and determine their eligibility for authorization upon the receipt of the failed part, the identification of the claimant, and the liftgate serial number. All parts must be returned freight prepaid and following the instructions given by the Anthony Warranty Department. Freight collect shipments will not be accepted.

PLEASE NOTE THAT NO CLAIMS WILL BE PROCESSED WITHOUT THE PART, THE CLAIMANT'S INFORMATION, AND THE LIFTGATE SERIAL NUMBER.

Claims not submitted within 30 days of repair date will be denied.

NOTE: ALL CLAIMS MUST BE COMPLETED ON THE ANTHONY LIFTGATES INC. WARRANTY CLAIM FORM.

This form provides all the necessary information.

Upon approval of the claim, Anthony will, at the direction of the claimant, return a replacement part and labor allowance, or a parts credit based on current distributor net pricing, and the appropriate flat rate labor allowance.

Anthony Liftgates, Inc. is not responsible or liable for loss of time, cost, labor, material, profits, direct or indirect damages caused by failed components, whether due to rights arising under purchase, order, contract of sale or independently thereof, and whether or not such claim is based on contract, tort, or warranty. The sale of products of Anthony Liftgates, Inc. under any other warranty or guarantee express or implied is not authorized. This warranty does not cover misuse, abuse, damage, or product finish, normal wear, maintenance adjustments, careless or negligence of use or maintenance. Modifications to our product are not covered unless prior authorized by Anthony.

Purchased Parts warranty is 1 year from date of purchase and covers replacement of part only.

If you require assistance or have questions, please contact Anthony Liftgates Inc. at 815-842-3383.

NOTE: Most (not all) Anthony liftgate models incorporate our Grease-Free feature. Grease-Free refers to the fact that these models require no routine or scheduled lubrication of the major pivot points that contain our Grease-Free bushings. Normal repair and maintenance of your liftgate, per our instruction, is necessary for ALL Anthony liftgates.

Anthony Liftgates, Inc.
1037 W. Howard St., P.O. Box 615
Pontiac, IL 61764-0615

PH: 815-842-3383
FAX: 815-844-3612
E-Mail: warrantyclaims@anthonyliftgates.com

12.2 Warranty Policy and Procedure

All warranty claims must be completed on the Anthony Liftgates Warranty Claim Form utilizing the Flat Rate Warranty Schedule. See the current rates as listed for each model. Using this process will allow for quick and accurate credit payment.

Claims will not be processed without the failed part returned (pre-paid) to Anthony Liftgates, and the warranty claim form completed.

NOTE: When returning defective parts for warranty consideration, be sure to call ahead for a Return Authorization Number.

If you require further assistance or have questions, please contact the Anthony Liftgates Warranty Dept. at 815-842-3383 or email: warrantyclaims@anthonyliftgates.com.

ANTHONY
LIFTGATES, INC.®

DCT



ANTHONY LIFTGATES, INC.
1037 W. HOWARD ST. • P.O. BOX 615
PONTIAC, IL 61764-0615
PH: 815-842-3383
FAX: 815-844-3612
TOLL FREE: 800-482-0003
WWW.ANTHONYLIFTGATES.COM